

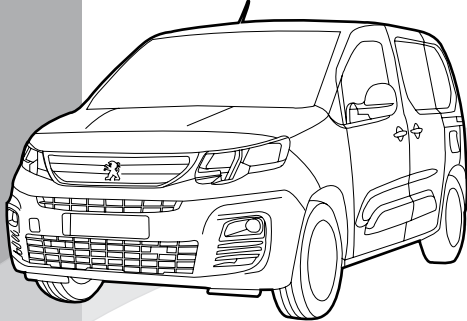

# Citroën Berlingo III + Van

06/'18-

~~XL~~



# Peugeot Partner III

09/'18-

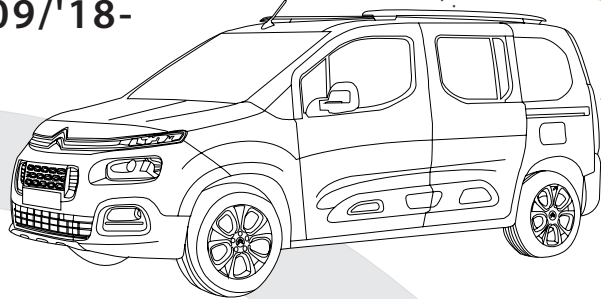

# Peugeot Rifter

09/'18-

~~XL~~

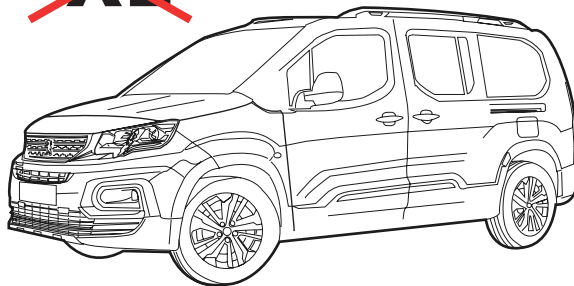

# Fiat Doblo

06/'22-

~~XL~~



**E-DOBLO**

# Toyota ProAce City

10/'19-

~~XL~~

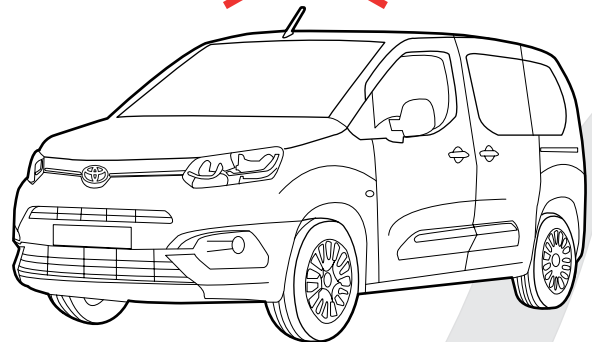

# Opel Combo E IV

# Combo Life

06/'18-

~~XL~~

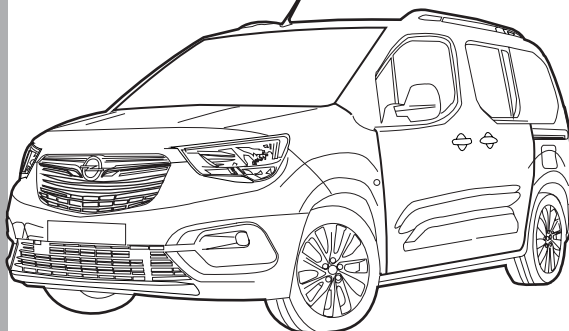

SCAN FOR  
THE LATEST VERSION



## NL Belangrijke raadgevingen

### Montage

- Voor de montage moet de trekhaak eerst op het voertuig gepresenteerd worden.

De belasting van een aanhangwagen en van een accessoire dat op de koppelingskogel wordt voorzien, zijn anders van aard. Voor beiden kunnen verschillende limieten van toepassing zijn. Hiervoor verwijzen we naar het instructieboekje van de wagen of naar uw concessiehouder.

## FR Recommandations importantes

### Montage

- Présenter l'attelage sous le véhicule avant d'effectuer le montage.

La charge d'une remorque ou d'un accessoire prévue sur la boule d'attelage, est de nature diverse. Pour ces deux éléments, il peut y avoir des limites d'utilisation. Nous vous recommandons de vous référer à votre livret d'instructions ou de vous renseigner chez votre concessionnaire.

## EN General instructions

### Fitting

- Present the towbar under the car first to check if all points are right.

The load of a trailer and of an accessory fitted on the towing ball are of a different nature. Different limits may apply to both. For this matter, we refer to the instruction manual of the vehicle or we advise you to contact your concessionaire.

## DE Wichtige ratschläge

### Montage

- Erst die Anhängerkupplung und das Fahrzeug kontrollieren, danach montieren.

Die Belastung eines Anhängers und eines Zubehörs, die man auf einer Kupplungskugel voraussieht, ist wesentlich anders. Für beide gilt, dass diese unterschiedlich begrenzt sein können. Deswegen möchten wir verweisen auf die Bedienungsanleitung des Fahrzeugs oder auf Ihren Vertragshändler.

## ES Instrucciones generales

### Montaje

- Presentar el enganche debajo del vehículo antes de realizar el montaje.

La carga de un remolque y un accesorio montado en una bola de remolque son de una naturaleza diferente. Se pueden aplicar diferentes límites a ambos. Para este asunto, nos referimos al manual de instrucciones del vehículo o le recomendamos que contacte a su distribuidor.

## DK Generelle instruktioner

### Montering

- Præsenter trækstangen under bilen først for at kontrollere, om alle punkter er rigtige.

Belastningen af en trailer og af tilbehør tilkoblet anhængertrækket er forskellige. Der kan være forskellige begrænsninger på begge. I disse tilfælde henviser vi til bilens manual, eller anbefaler dig at kontakte bilforhandleren



## IT Consigli importanti

### Montaggio

- In primo luogo, presentare la struttura sotto l'automobile per verificare che tutti i punti di attacco coincidano.

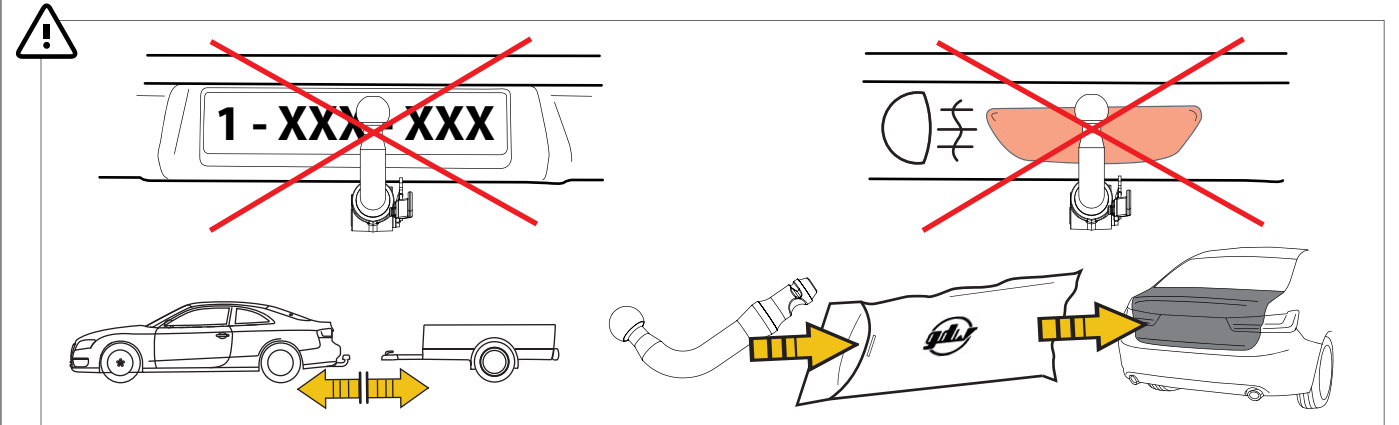
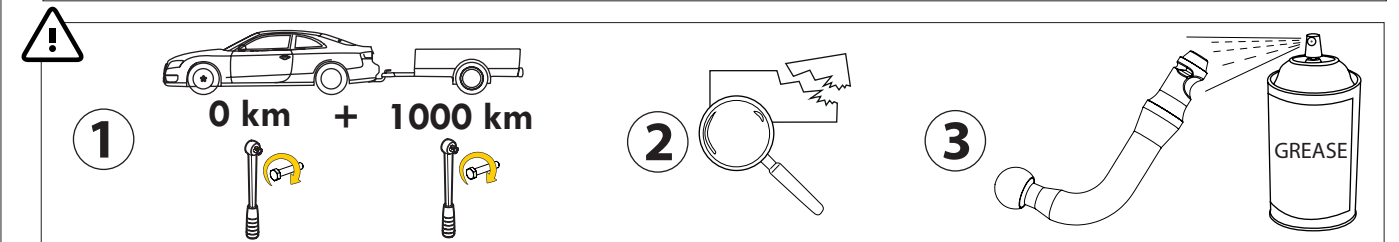
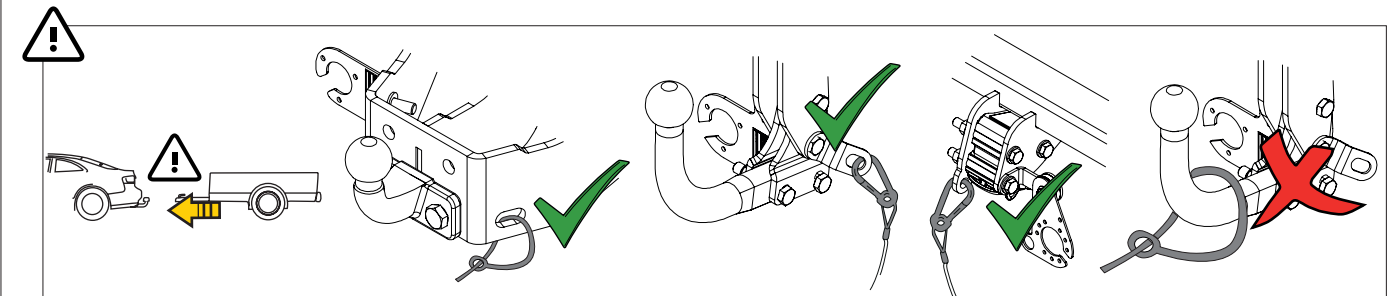
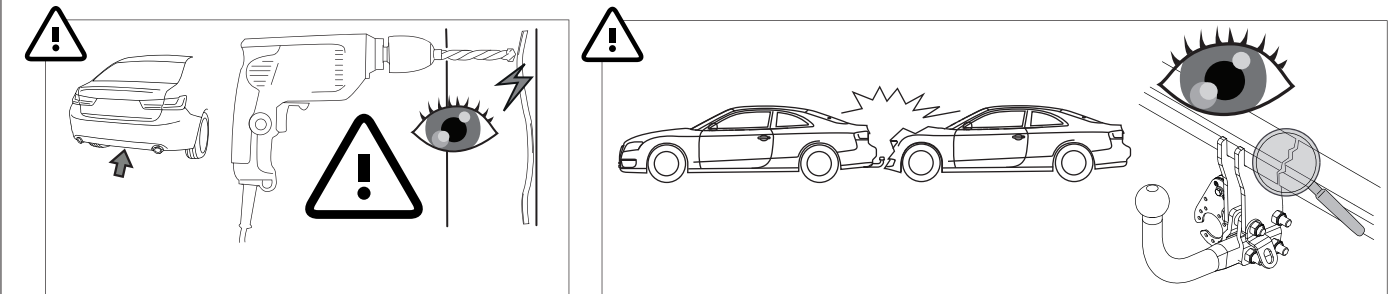
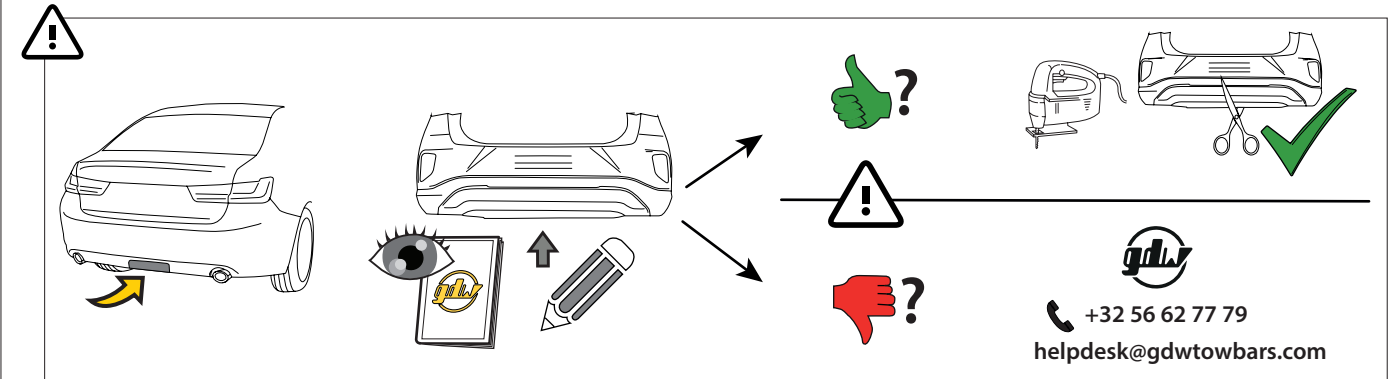
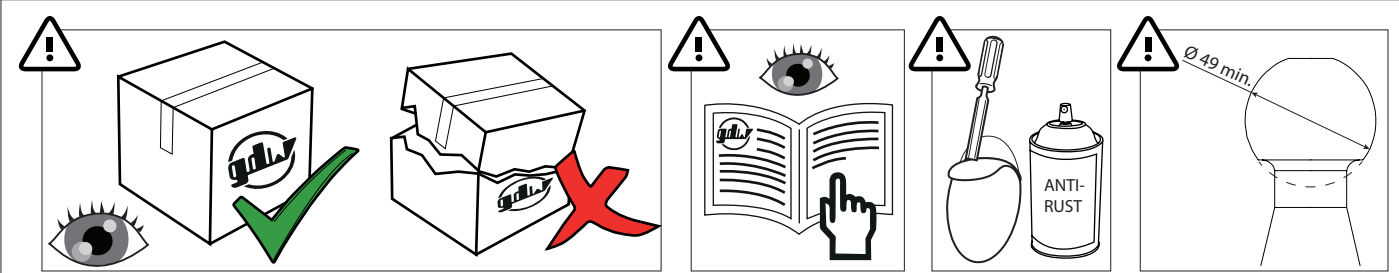
La massa rimorchiabile del veicolo potrebbe essere diversa dal valore riportato sul documento del gancio di traino. Per questo motivo, vi invitiamo a consultare sempre la carta di circolazione del veicolo (Pos. O.1) o a rivolgervi alla vostro concessionario di fiducia



MADE BY  <b>D 8,65</b>	<b>F</b>	<b>E6</b>	  $D = \frac{\text{max kg} \times \text{max kg}}{\text{max kg} + \text{max kg}} \times 0.00981 \leq 8,65 \text{ kN}$
BELGIUM <b>S 80</b>	EC-N° 55R-01 1488		
REF N° B01302	SERIAL N° XXXX		$S = \begin{matrix} \downarrow \\ \text{hook} \end{matrix} \leq 80 \text{ kg} \quad \begin{matrix} \downarrow \\ \text{bar} \end{matrix} \leq 1500 \text{ kg}$
<b>DESCRIPTION</b> Citroën Berlingo 08/08- / Peugeot Partner 08/08- / Fiat Doblo 06/22- Peugeot Rifter 09/18- / Opel Combo 06/18- / Toyota ProAce City 10/19-			

See the Certificate Of Conformity (COC) of your vehicle or contact your dealer to verify the max. trailer weight of your car!

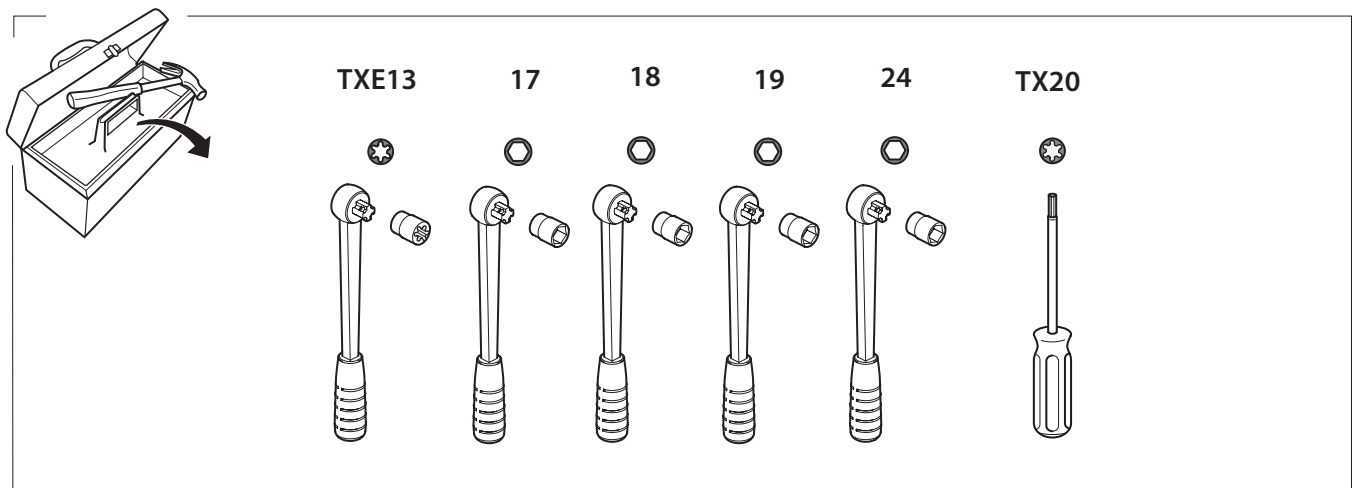
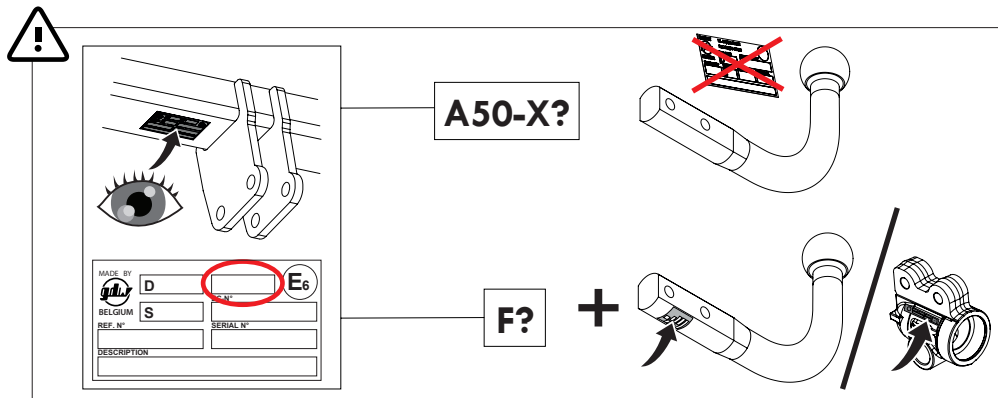
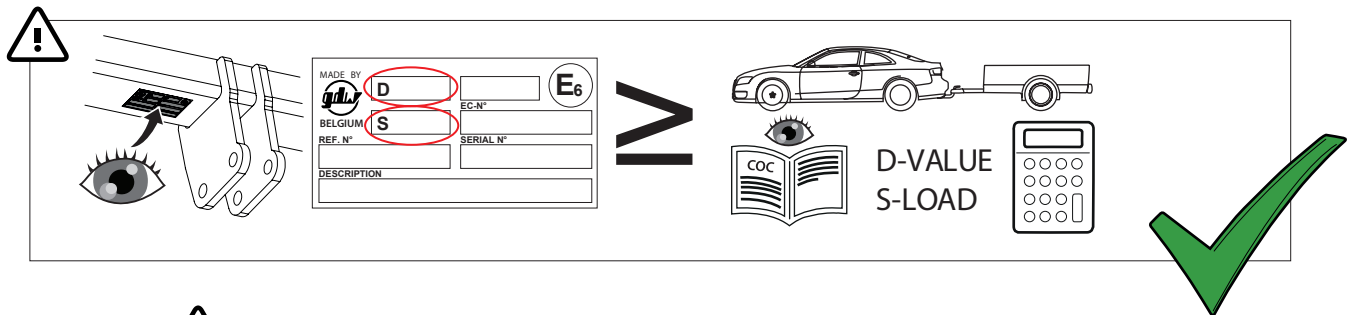
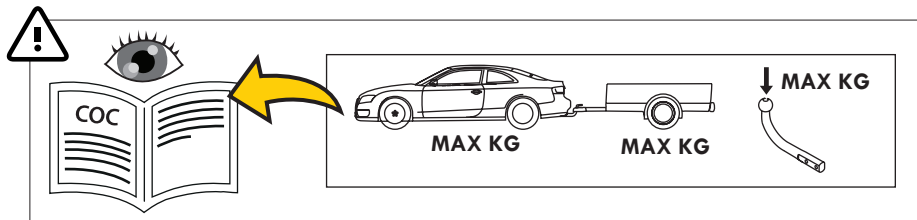



**helpdesk@gdwtowbars.com**

**+32 56 62 77 79**



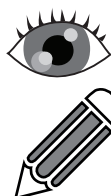



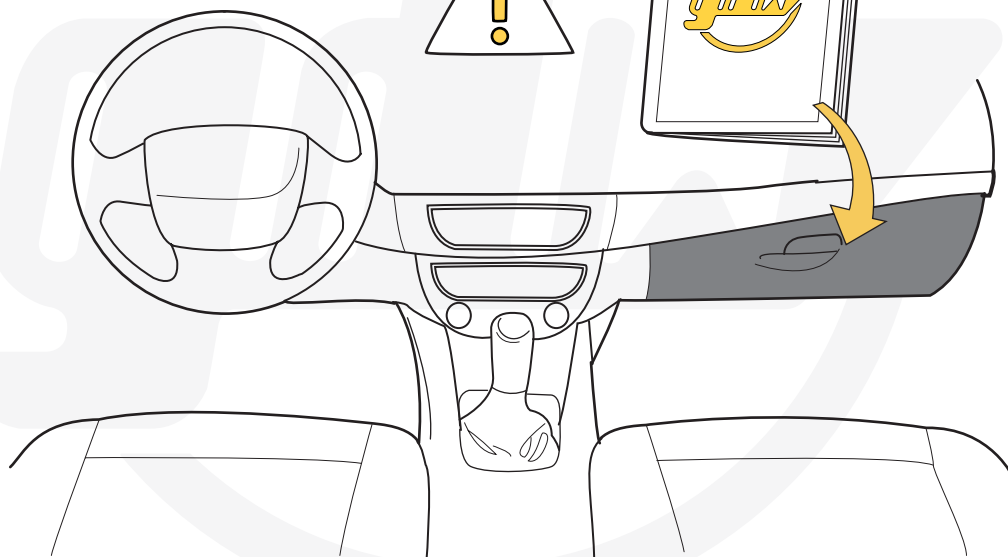

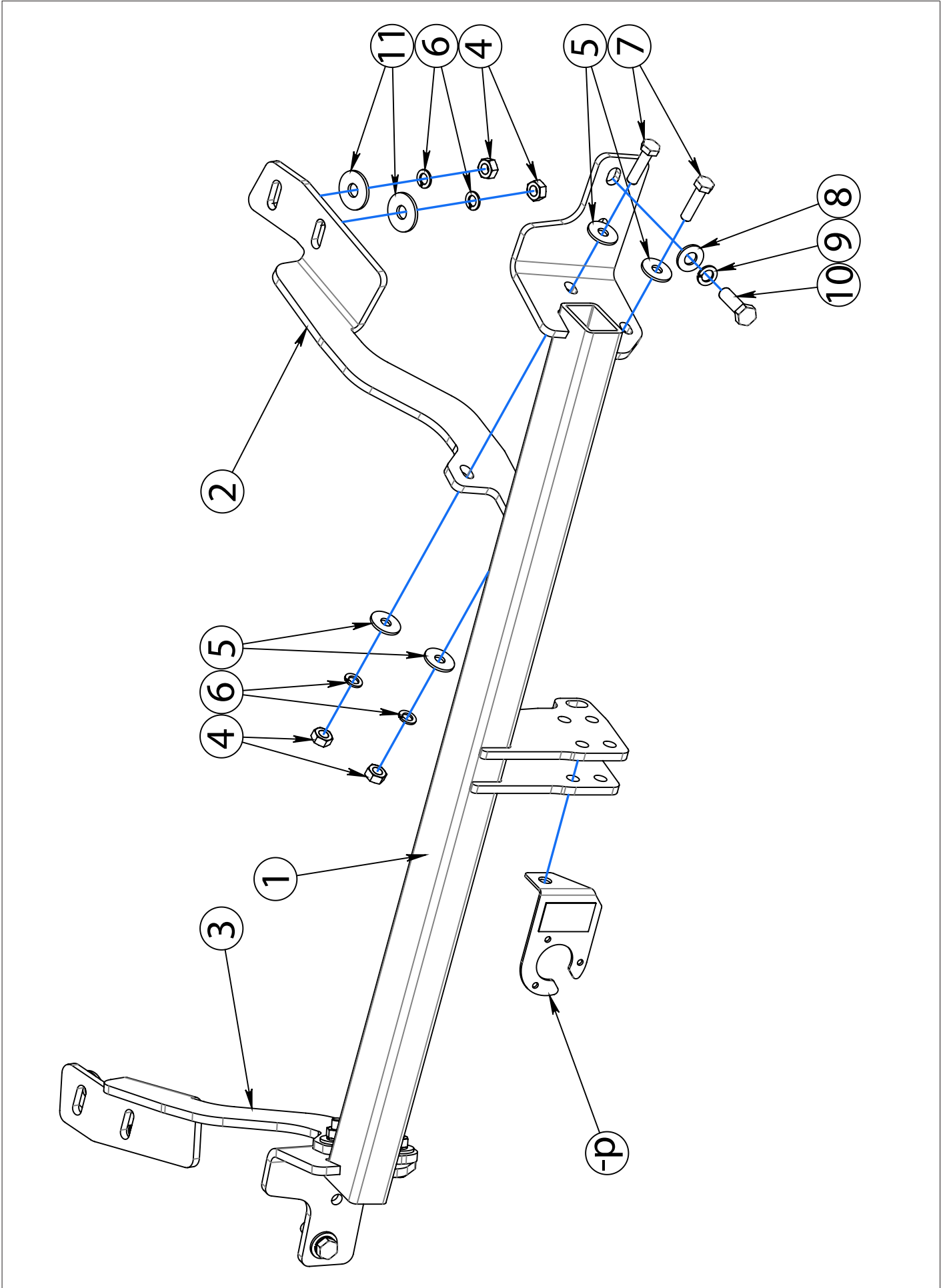

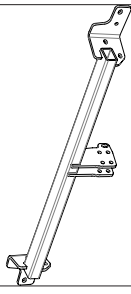
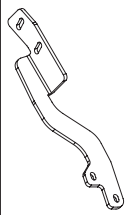
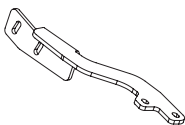
Monday	08:00 - 12:00	12:30 - 16:30
Tuesday	08:00 - 12:00	12:30 - 16:30
Wednesday	08:00 - 12:00	12:30 - 16:30
Thursday	08:00 - 12:00	12:30 - 16:30
Friday	08:00 - 12:00	12:30 - 15:30









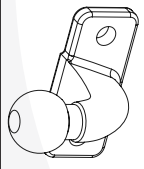
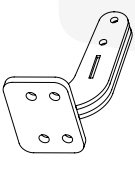

**KEY NUMBER**





1		X1	GDW REF. - B01302
2		X1	GDW REF. 2
3		X1	GDW REF. 3
4		x8	DIN934-M10
5		x8	DIN9021-10,5 X 30 X 2,5
6		x8	DIN128A-M10
7		x4	DIN933-M10 X 40
8		x2	NFE 25-513 13 X 27 X 2,5
9		x2	DIN128A-M12
10		x2	DIN933-M12 X 40
11		x4	DIN9021-13 X 37 X 3
-V		X1	PRISE PLIEE

<p>Geleverd met - Livré avec - Delivered with          Geliiefert mit - Elementos adjuntos-Leveres med</p>		X1	REF. REZ50
		X1	SUPPORT REZ
		X2	DIN933-M16 X 50
		X2	DIN125 17 X 30 X 3
		X2	DIN128A-M16
		X2	DIN934-M16
		X2	DIN931-M12 X 70
		X2	DIN934-M12
		X2	DIN128A-M12
		X2	ENTRETOISE 21.7 X 16 X 11.7

1

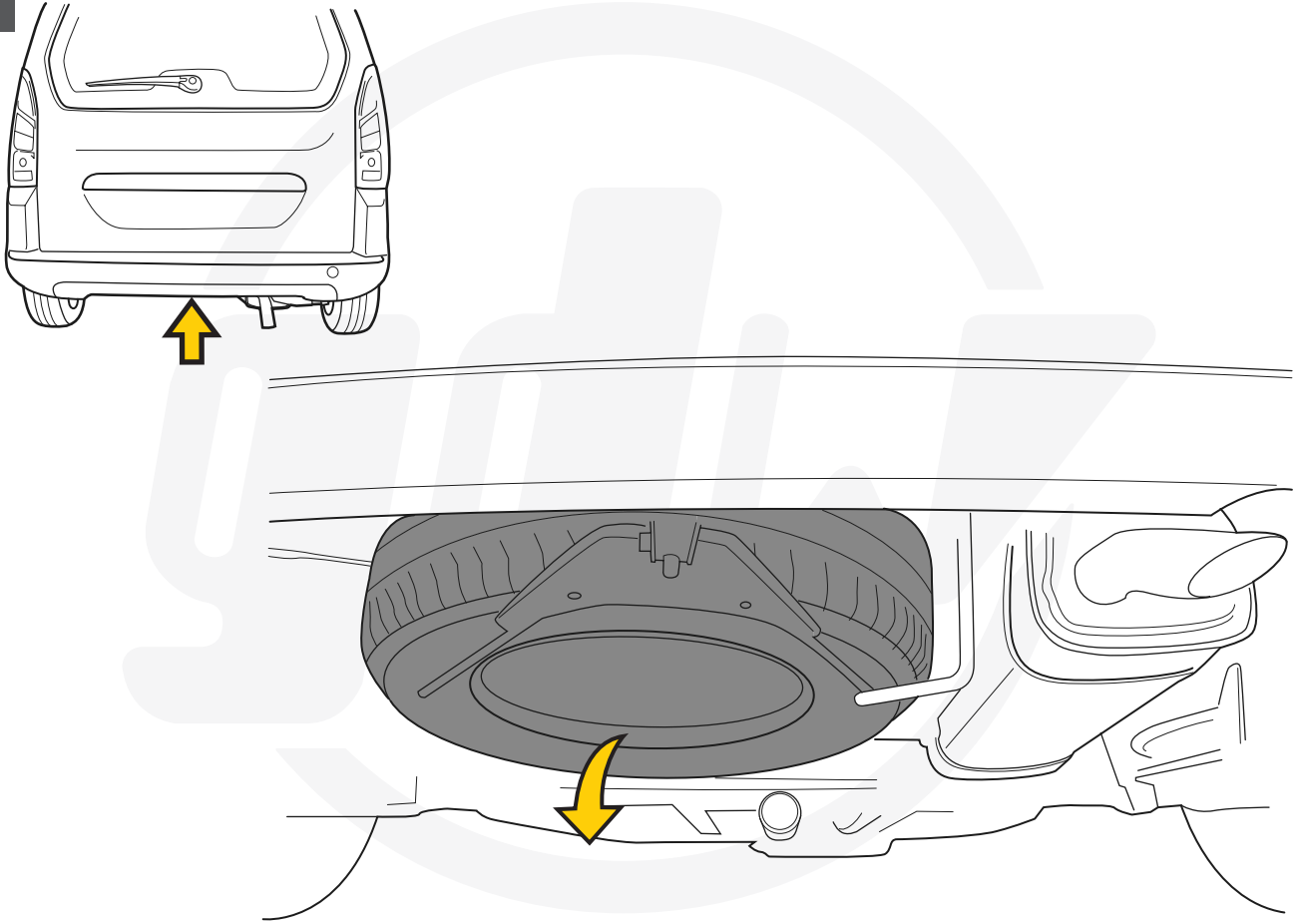

2

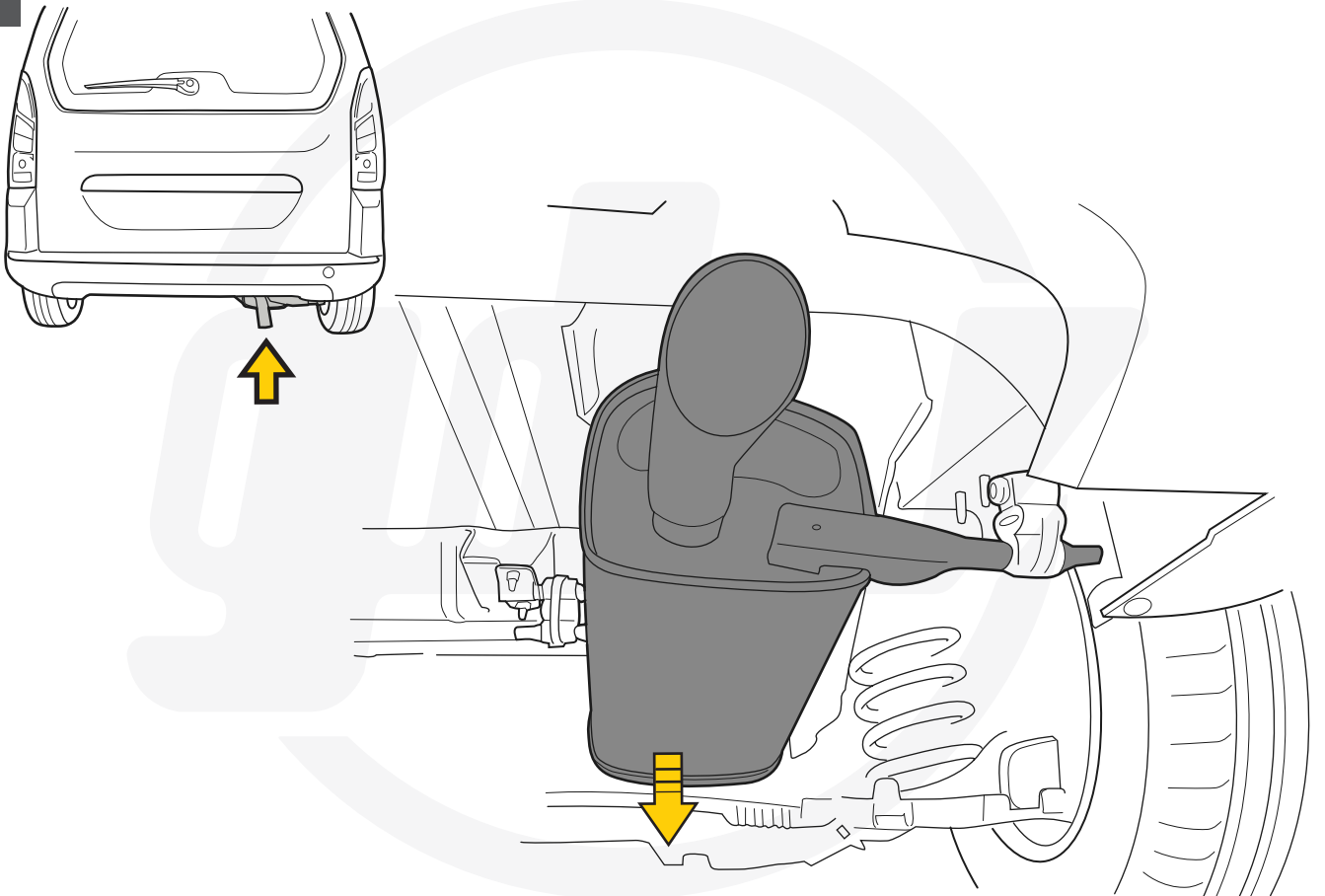

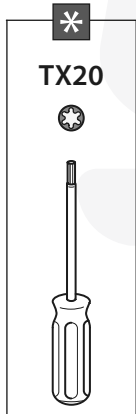
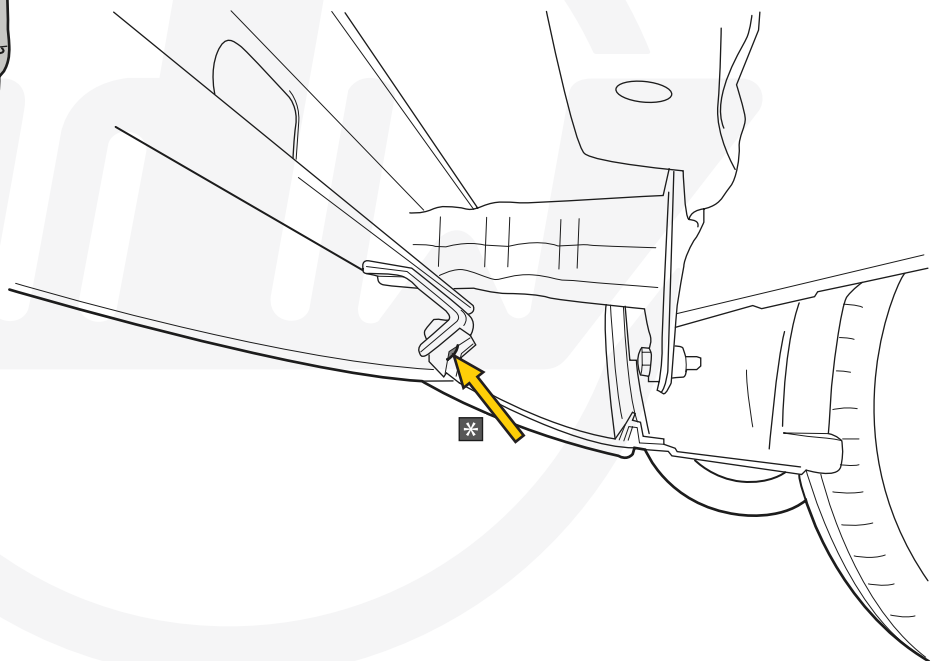
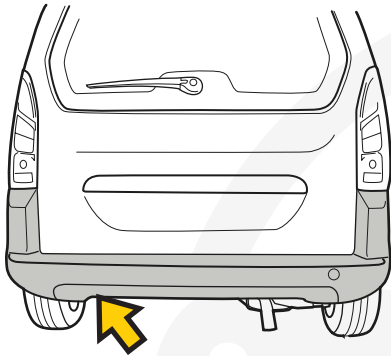
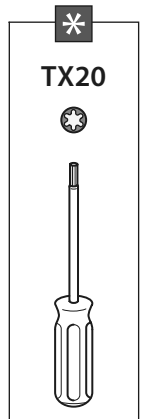
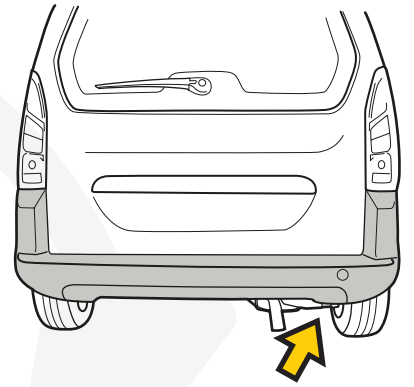
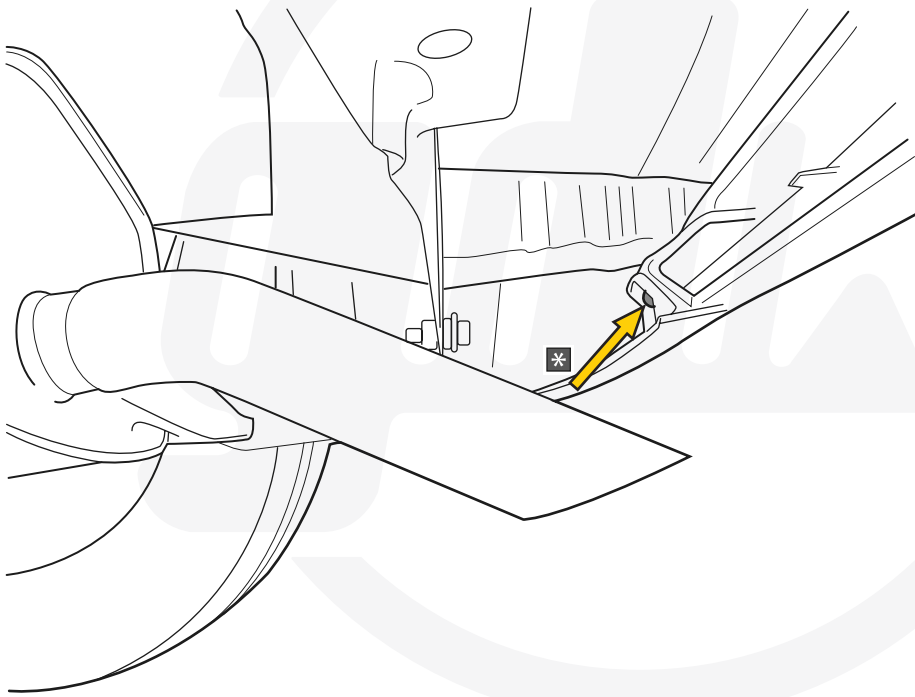

5

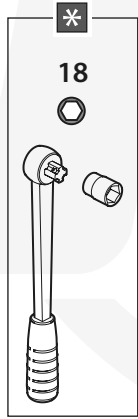
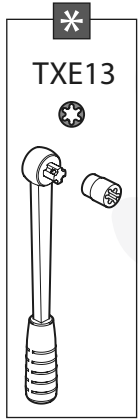
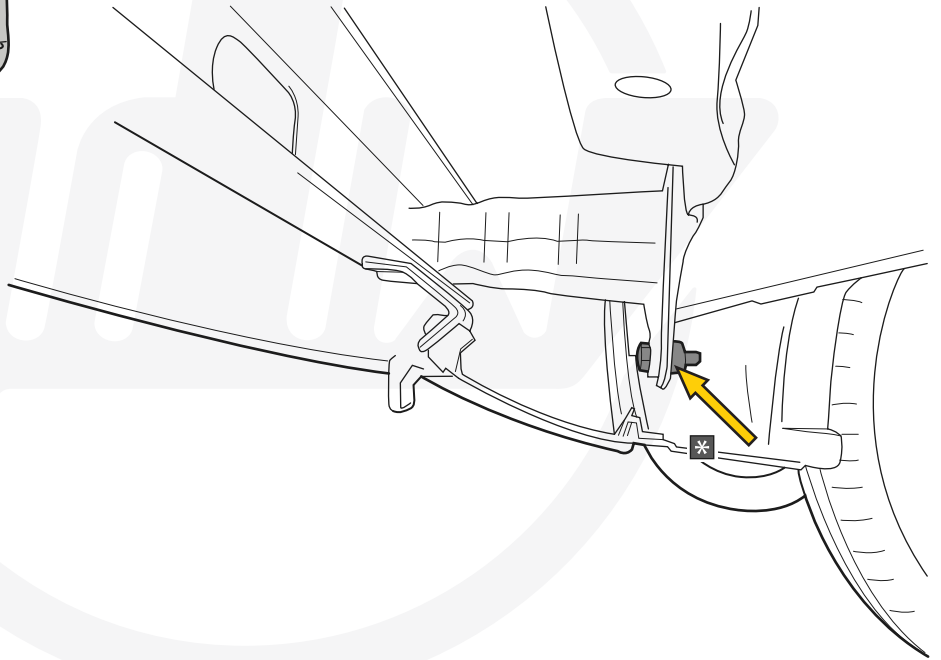
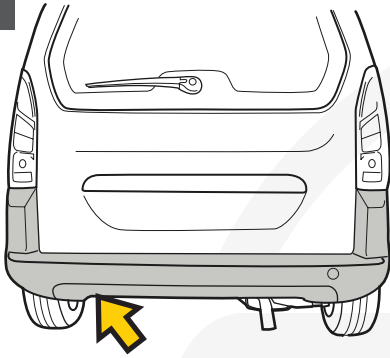

6

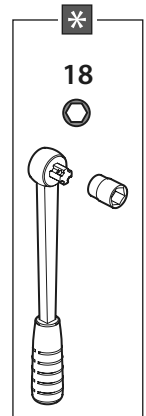
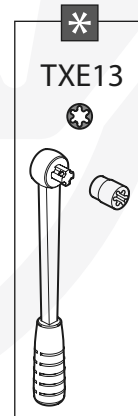
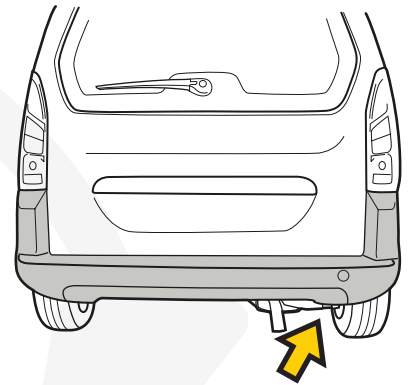
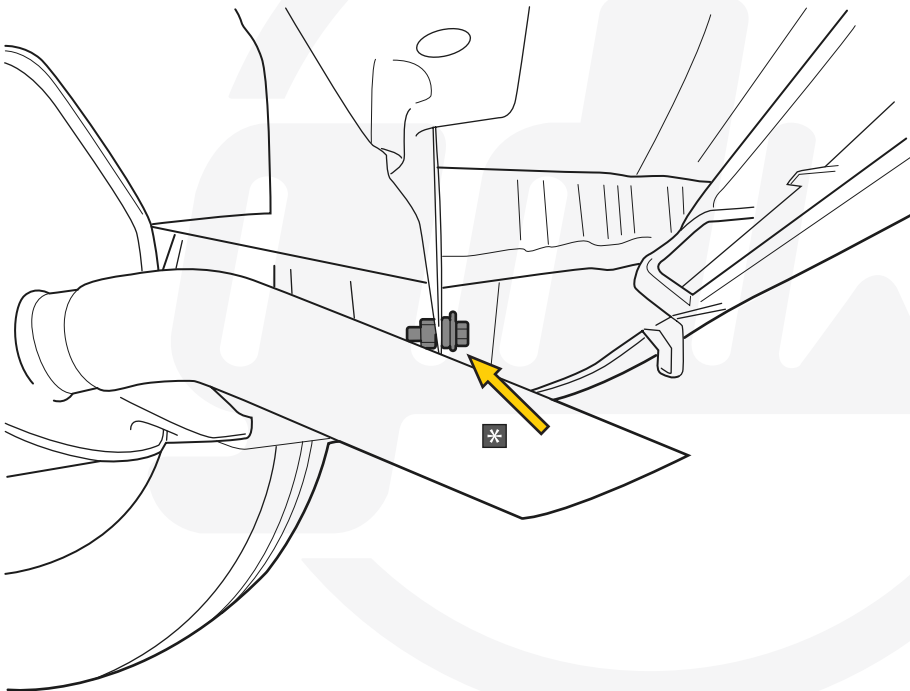

7

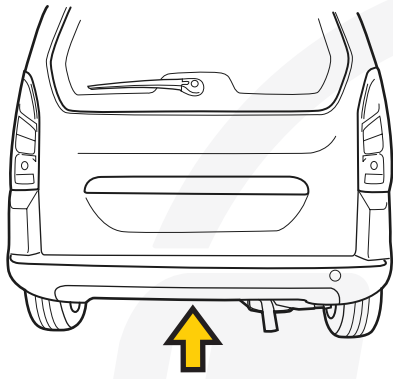

93,0 Nm

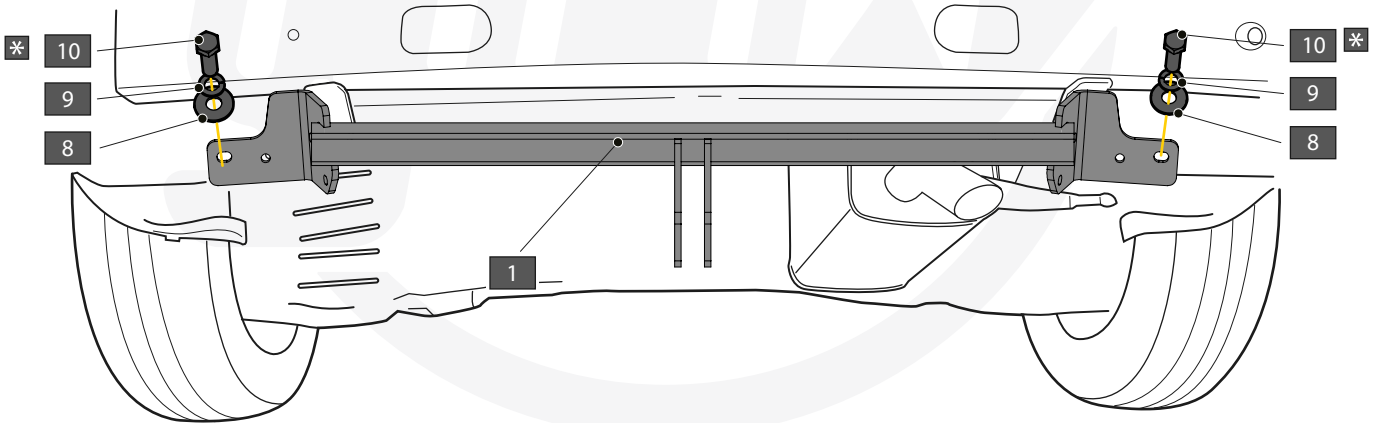
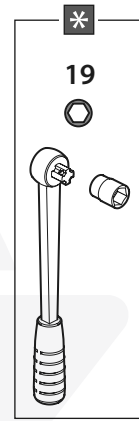

8

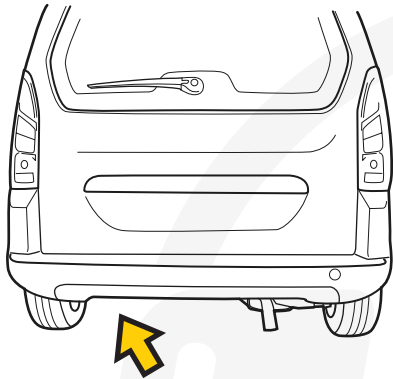

54,0 Nm

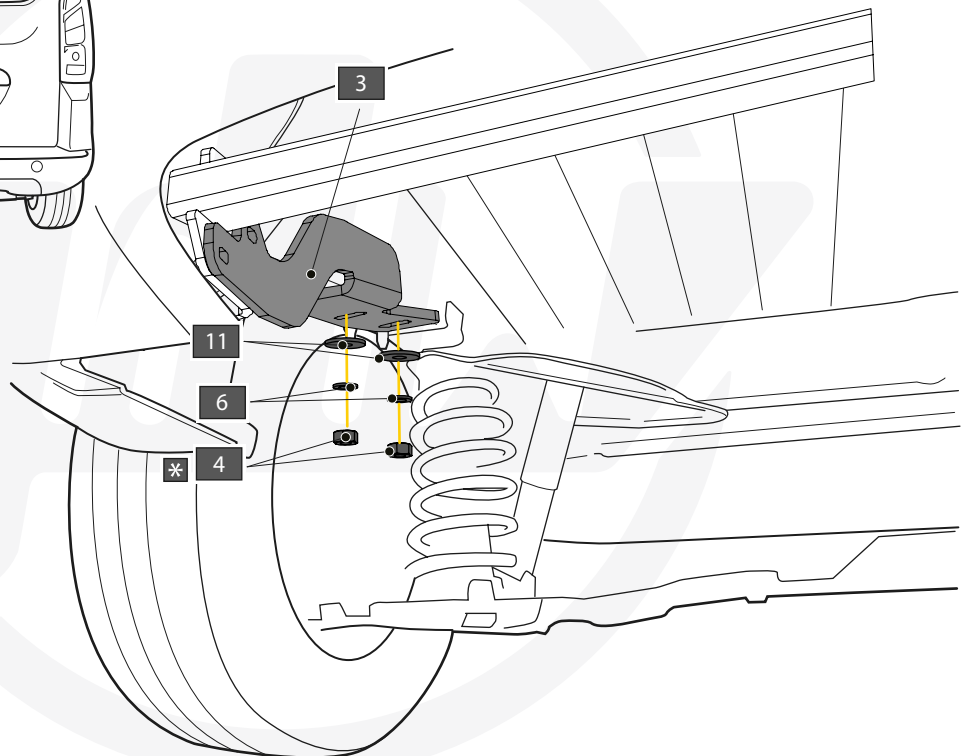
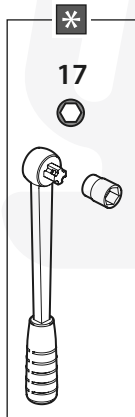

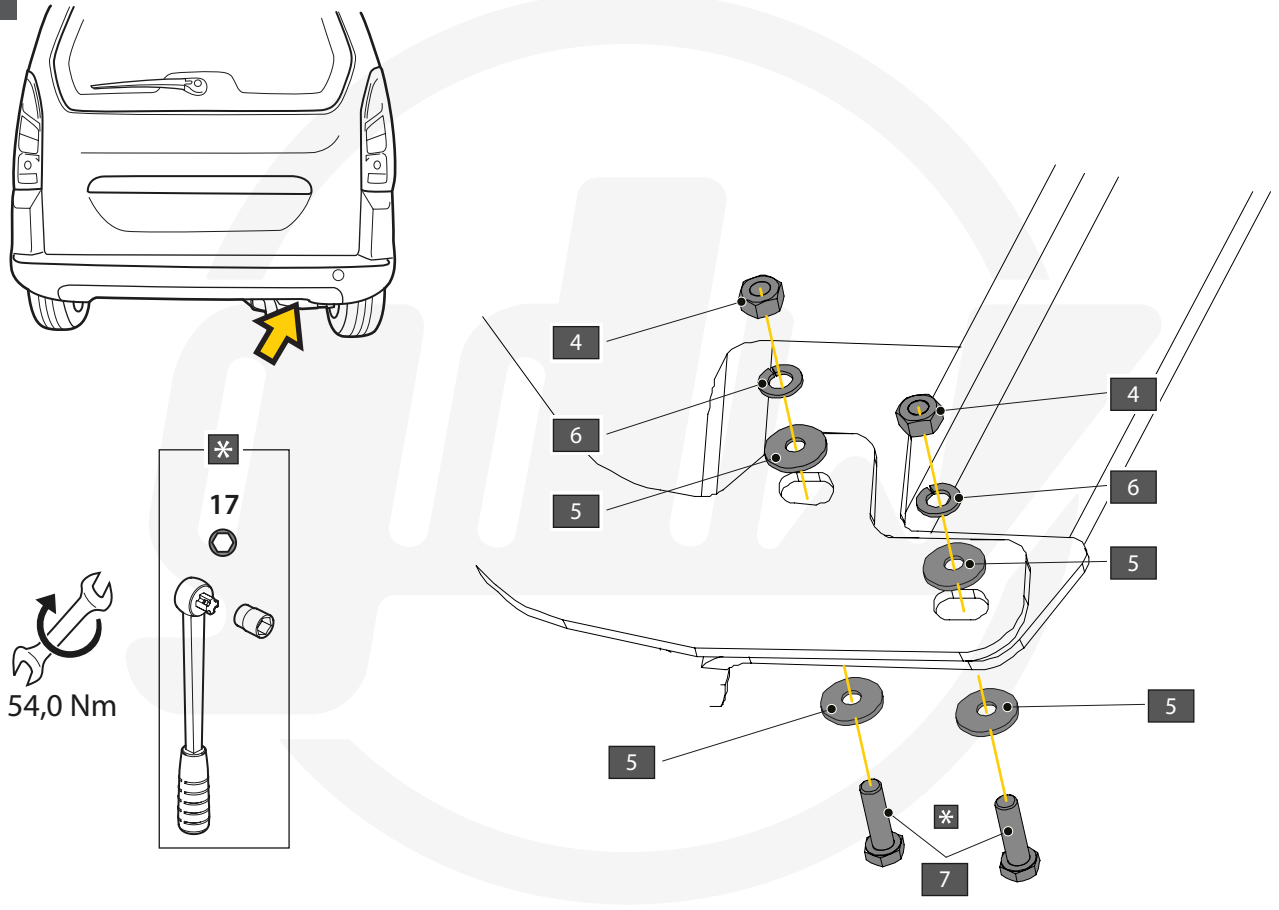
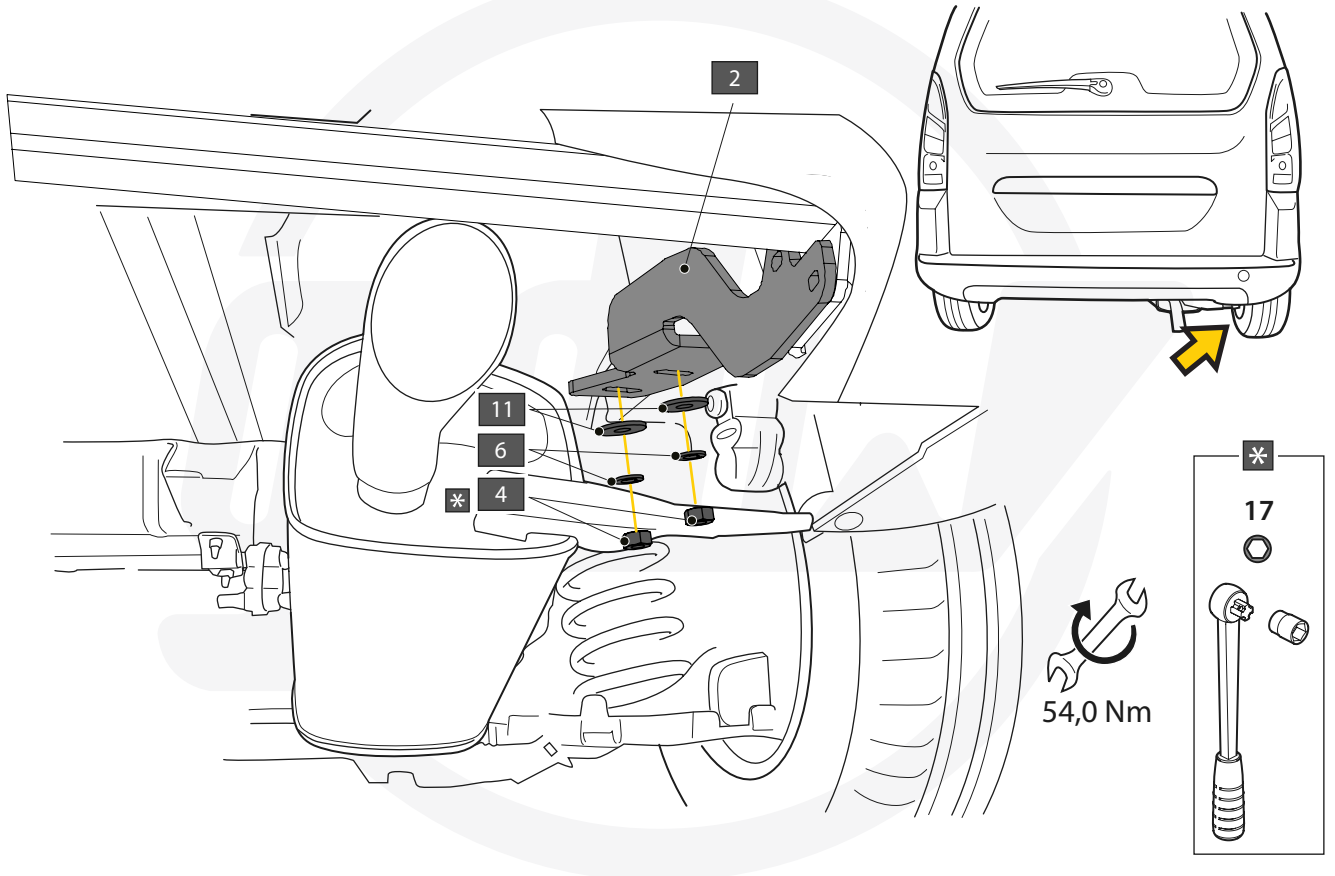

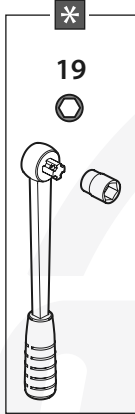
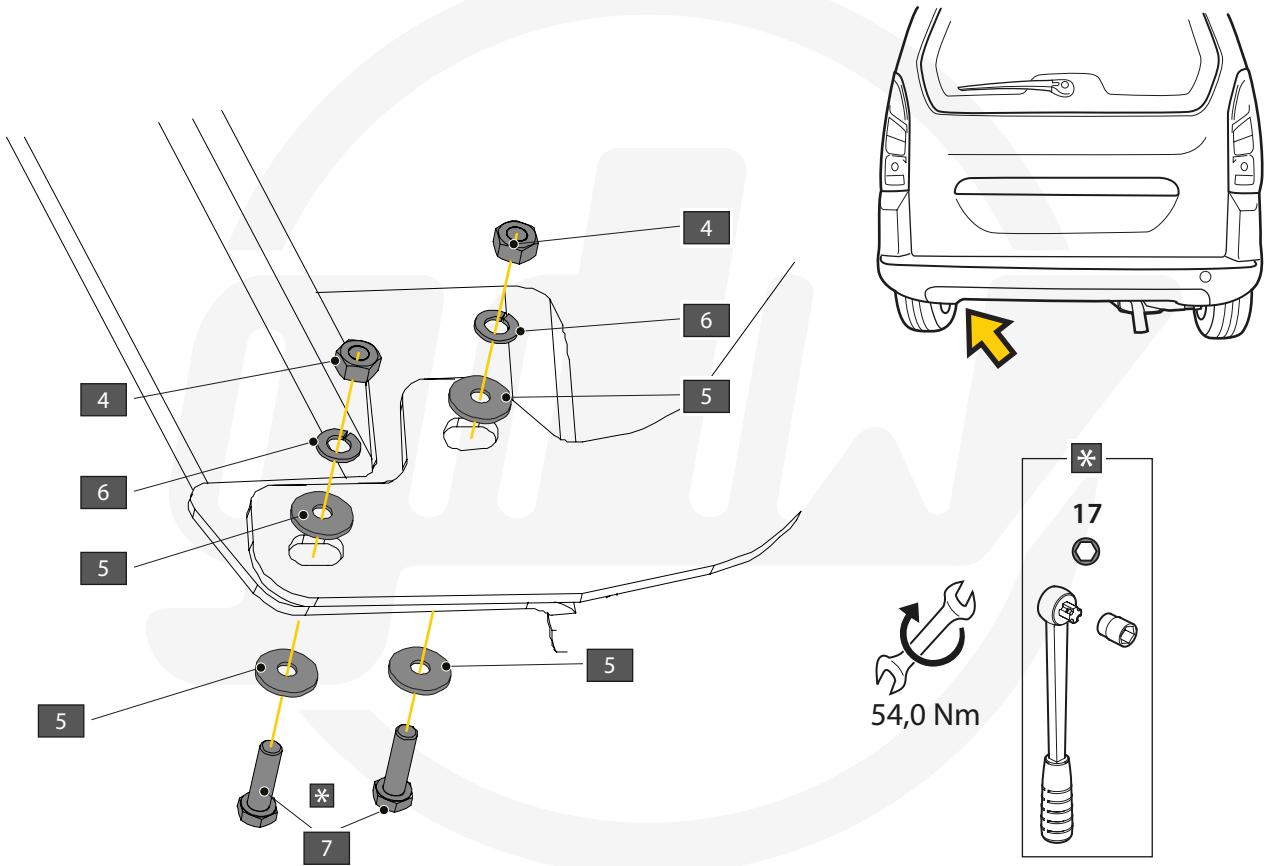

**BERLINGO & COMBO  
& PARTNER**

**RIFTER**

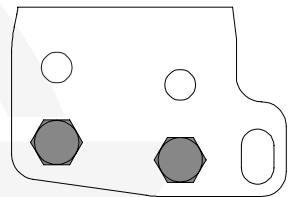
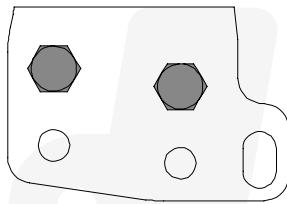



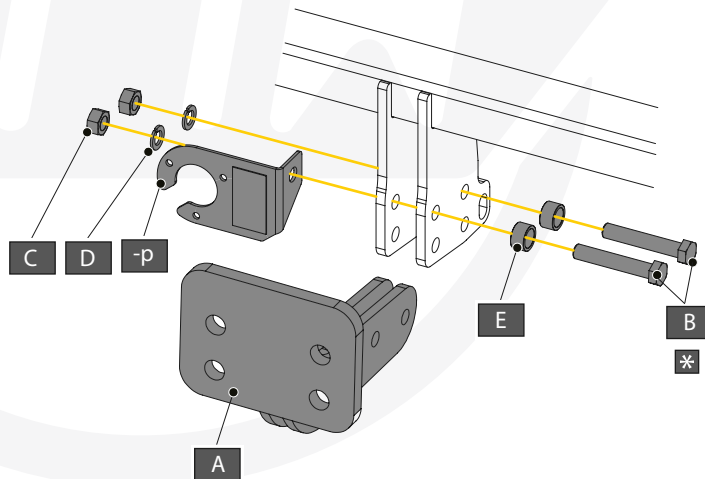

A		X1	SUPPORT REZ
B		X2	DIN931-M12 X 70
C		X2	DIN934-M12
D		X2	DIN128A-M12
E		X2	ENTRETOISE 21,7 X 16 X 11,7
-P		X1	PRISE PLIEE

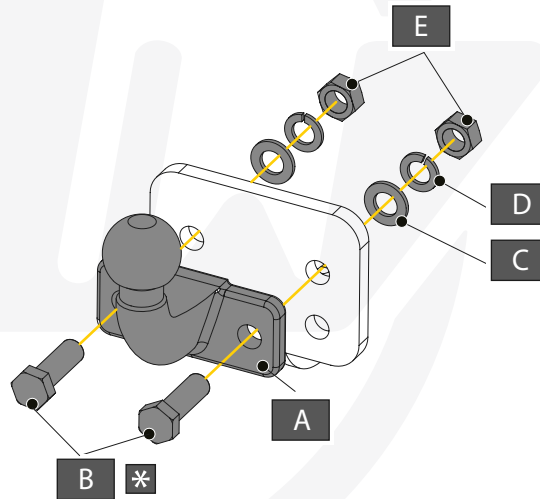
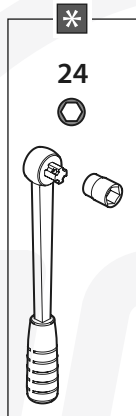

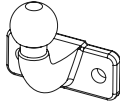
  
230,0 Nm



A		X1	REZ50
B		X2	DIN933-M16 X 50
C		X2	DIN125 17 X 30 X 3
D		X2	DIN128A-M16
E		X2	DIN934-M16

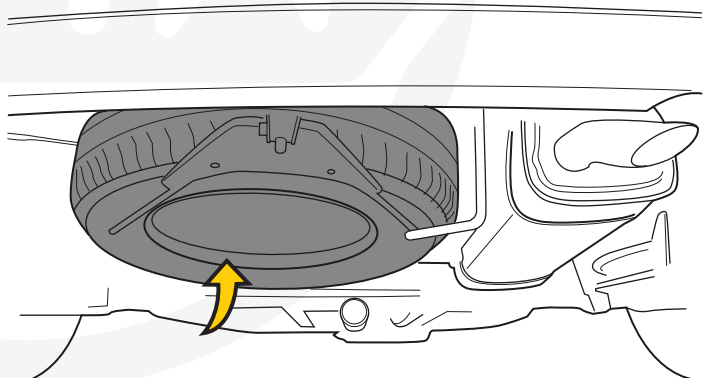
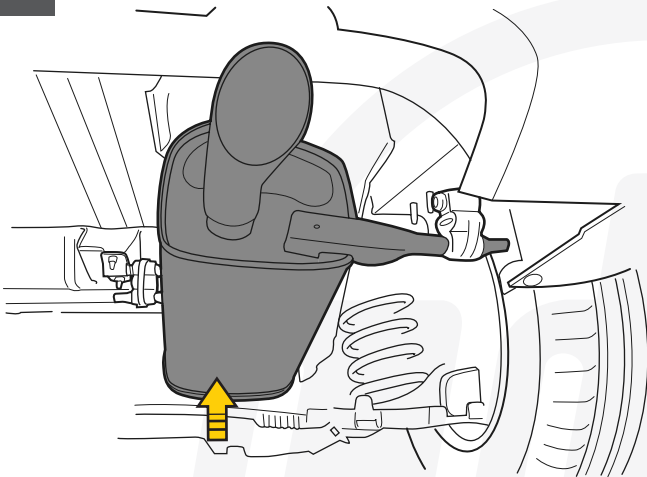

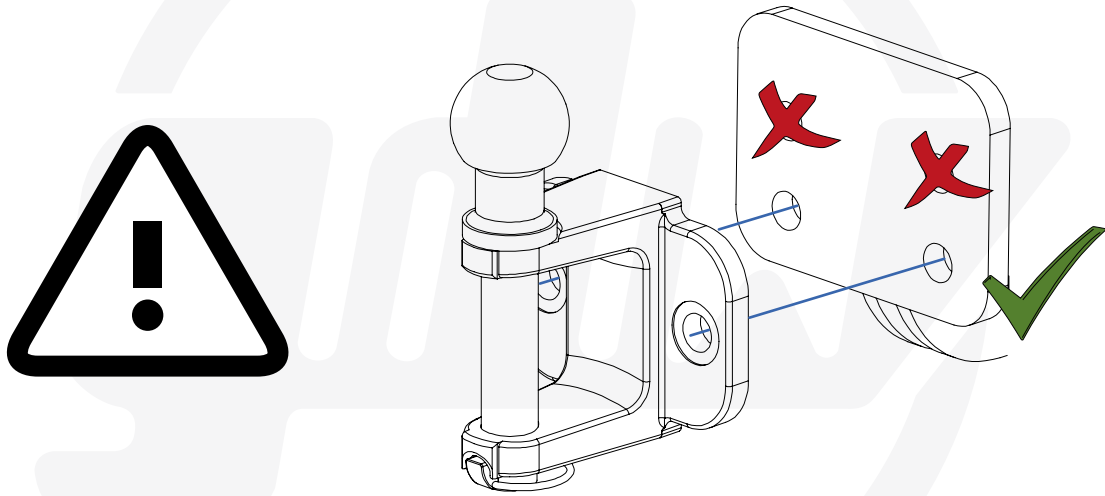

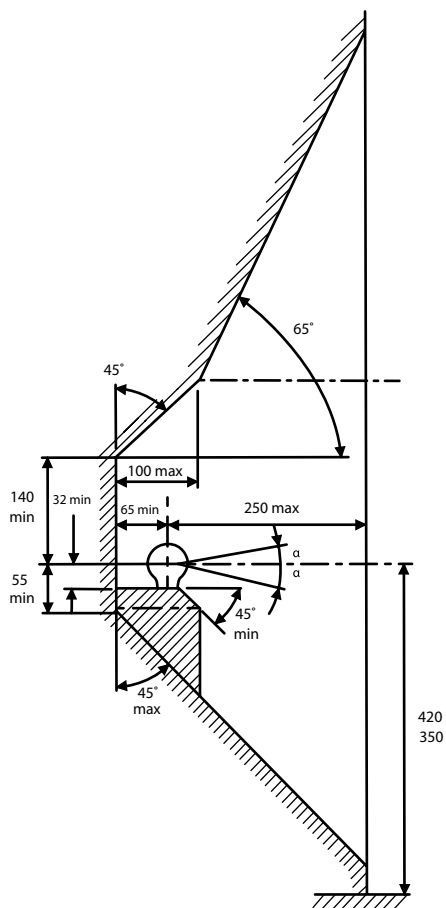

De tussenruimte conform bijlage VII, afbeelding 25 (a, b) van het reglement R55 UN/ECE moet in acht genomen worden. Deze voorschriften zijn niet van toepassing op terreinvoertuigen klasse G.

La zone de dégagement doit être garantie conformément à l'annexe VII, illustration 25 (a, b) de la règle R55 UN/ECE. Ces dispositions ne s'appliquent pas aux véhicules tout-terrain classe G.

The clearance specified in appendix VII, diagram 25 (a, b) of regulation R55 UN/ECE must be guaranteed. These requirements shall not apply to all-terrain vehicles class G.

Der Freiraum nach Anhang VII, Abbildung 25 (a, b) der Regulierung R55 UN/ECE ist zu gewährleisten. Diese Vorschriften gelten nicht für Geländefahrzeuge Klasse G.

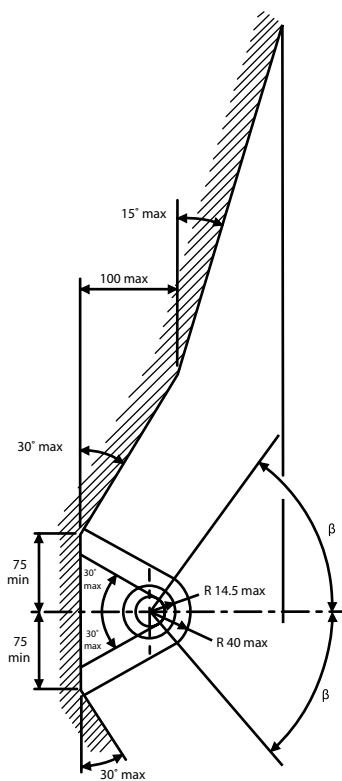

Bij toelaatbaar gewicht van het voertuig

Pour poids total en charge autorisé du véhicule

At laden weight of the vehicle

Bei zulässigem Gesamtgewicht des Fahrzeuges

Peso total admisible del vehículo

Ved tilladt samlet vægt for køretøjet

Peso totale ammissibile del veicolo