



TREKHAKEN • ATTELAGES • ANHÄNGERVORRICHTUNGEN • TOWBARS • ENHANCES • ANHÆNGERTRÆK
Montagehandleiding | instructions de montage | Einbauanleitung | Mounting instruction
Instrucciones de montaje | monteringsvejledning



Renault Master III Type X82 (chassis cabine)

05/'10-05/'25 FRONT WHEEL DRIVE / REAR WHEEL DRIVE

Renault Master IV Type XDE (chassis cabine)

06/'24- FRONT WHEEL DRIVE / REAR WHEEL DRIVE

Opel Movano Type X62 (chassis cabine)

05/'10- FRONT WHEEL DRIVE / REAR WHEEL DRIVE

Nissan NV400 Type X62 (chassis cabine)

11/'11-10/'21 FRONT WHEEL DRIVE / REAR WHEEL DRIVE

Nissan Interstar Type X62 (chassis cabine)

11/'21- 08/'24 FRONT WHEEL DRIVE / REAR WHEEL DRIVE

Nissan Interstar Type XDE (chassis cabine)

09/'24 - FRONT WHEEL DRIVE / REAR WHEEL DRIVE

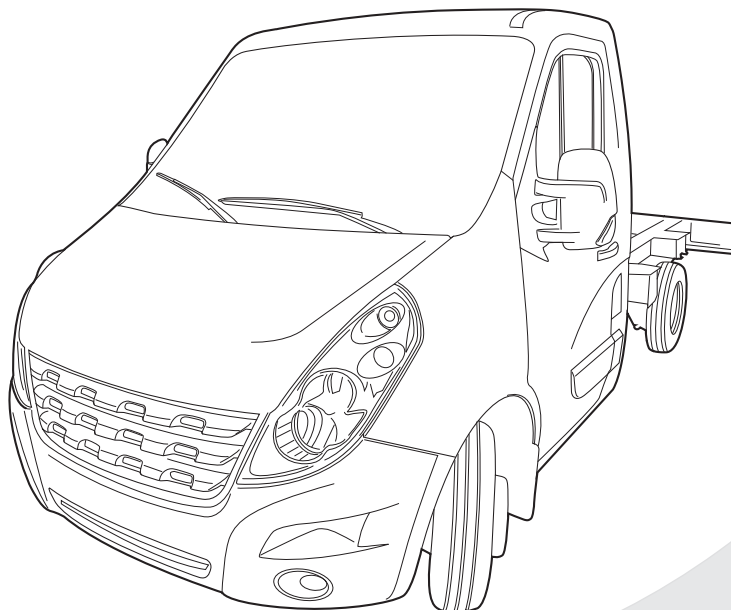

SCAN FOR THE
LATEST VERSION



NL Belangrijke raadgevingen

Montage

- Voor de montage moet de trekhaak eerst op het voertuig gepresenteerd worden.

De belasting van een aanhangwagen en van een accessoire dat op de koppelingskogel wordt voorzien, zijn anders van aard. Voor beiden kunnen verschillende limieten van toepassing zijn. Hiervoor verwijzen we naar het instructieboekje van de wagen of naar uw concessiehouder.

FR Recommandations importantes

Montage

- Présenter l'attelage sous le véhicule avant d'effectuer le montage.

La charge d'une remorque ou d'un accessoire monté sur la boule d'attelage, sont de nature différentes. Des limites différentes peuvent s'appliquer à l'un et à l'autre. Nous vous recommandons de vous référer à votre livret d'instructions ou de vous renseigner chez votre concessionnaire.

EN General instructions

Fitting

- Present the towbar under the car first to check if all points are right.

The load of a trailer and of an accessory fitted on the towing ball are of a different nature. Different limits may apply to both. For this matter, we refer to the instruction manual of the vehicle or we advise you to contact your concessionaire.

DE Allgemeine Hinweise

Montage

- Halten Sie die Anhängerkupplung zunächst unter das Fahrzeug und prüfen Sie, ob alle Punkte übereinstimmen.

Die Last eines Anhängers und die Last eines an der Zugkugel montierten Zubehörs unterscheiden sich grundsätzlich. Für beide können unterschiedliche Grenzwerte gelten. Wir verweisen diesbezüglich auf die Betriebsanleitung des Fahrzeugs oder empfehlen Ihnen, sich an Ihren Vertragshändler zu wenden.

ES Instrucciones generales

Montaje

- Presentar el enganche debajo del vehículo antes de realizar el montaje.

La carga de un remolque y un accesorio montado en una bola de remolque son de una naturaleza diferente. Se pueden aplicar diferentes límites a ambos. Para este asunto, nos referimos al manual de instrucciones del vehículo o le recomendamos que contacte a su distribuidor.

DK Generelle instruktioner

Montering

- Præsenter trækstangen under bilen først for at kontrollere, om alle punkter er rigtige.

Belastningen af en trailer og af tilbehør tilkoblet anhängertræk er forskellige. Der kan være forskellige begrænsninger på begge. I disse tilfælde henviser vi til bilens manual, eller anbefaler dig at kontakte bilforhandleren

IT Consigli importanti

Montaggio

- In primo luogo, presentare la struttura sotto l'automobile per verificare che tutti i punti di attacco coincidano.

La massa rimorchiabile del veicolo potrebbe essere diversa dal valore riportato sul documento del gancio di traino. Per questo motivo, vi invitiamo a consultare sempre la carta di circolazione del veicolo (Pos. O.1) o a rivolgervi alla vostro concessionario di fiducia

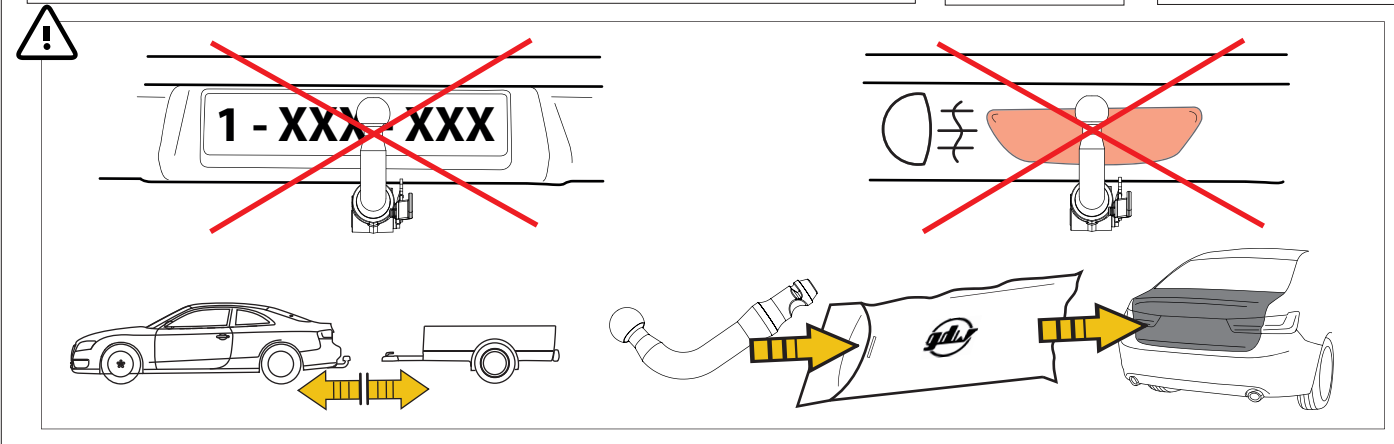
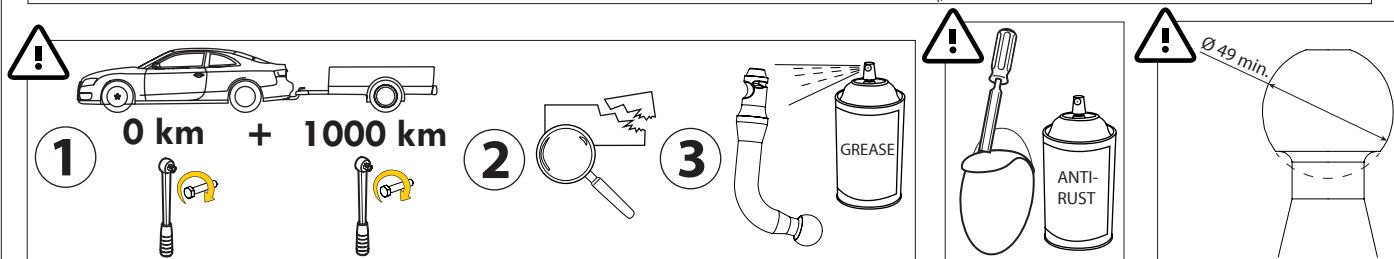
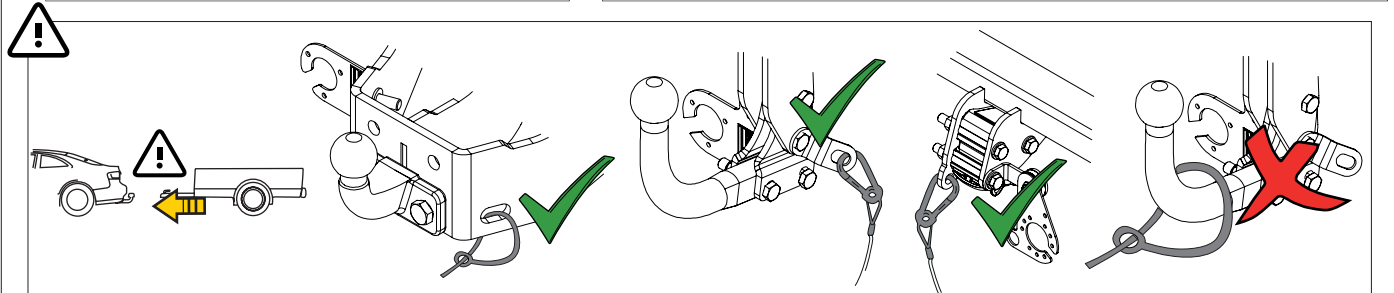
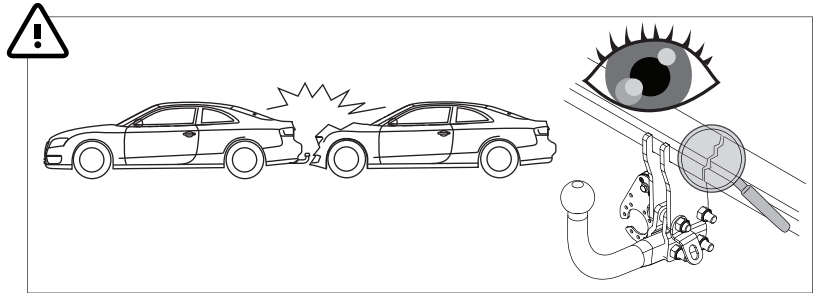
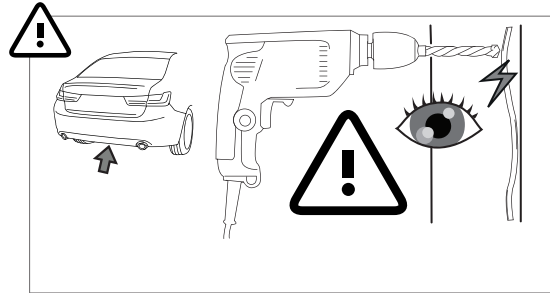
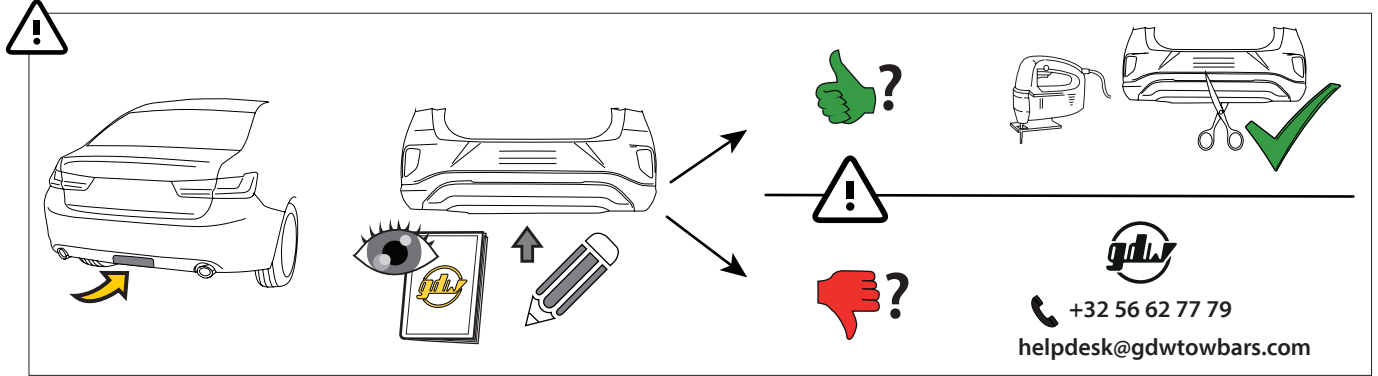
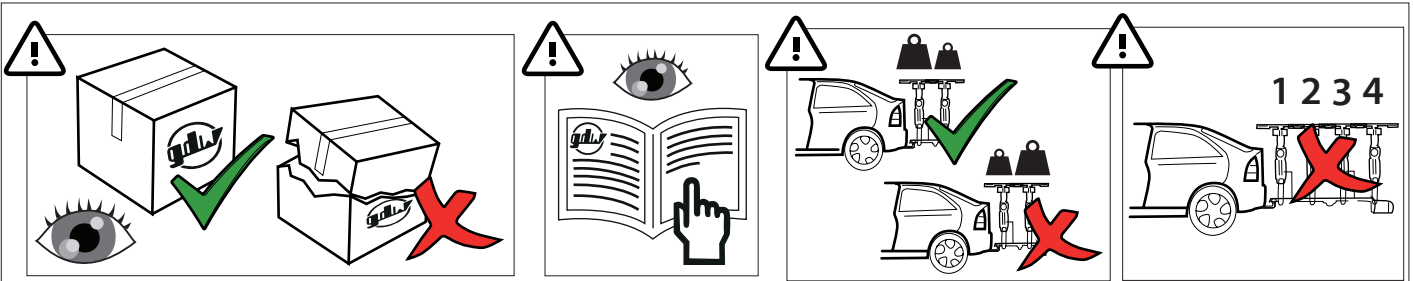

MADE BY



D 15,15

F

E6

BELGIUM

S 115

EC-N°

55R-02 1857

REF N°

2866

SERIAL N°

XXXX

DESCRIPTION

RENAULT MASTER III '10- + MASTER IV '24- / OPEL MOVANO '10-
NISSAN NV400 '11- / NISSAN INTERSTAR '21-



$$D = \frac{\text{max kg (car)} \times \text{max kg (trailer)}}{\text{max kg (car)} + \text{max kg (trailer)}} \times 0.00981 \leq 15,15 \text{ kN}$$

$$S = \begin{matrix} \downarrow \\ \text{hook} \end{matrix} \leq 115 \text{ kg} \quad \begin{matrix} \downarrow \\ \text{trailer} \end{matrix} \leq 2500 \text{ kg}$$



See the Certificate Of Conformity (COC) of your vehicle or contact your dealer to verify the max. trailer weight of your car!



See the user manual of the vehicle for correct use of bicycle carriers!

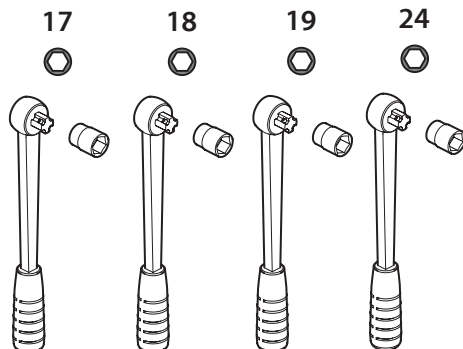
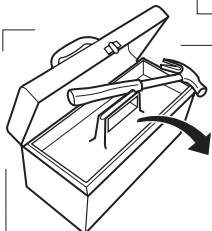
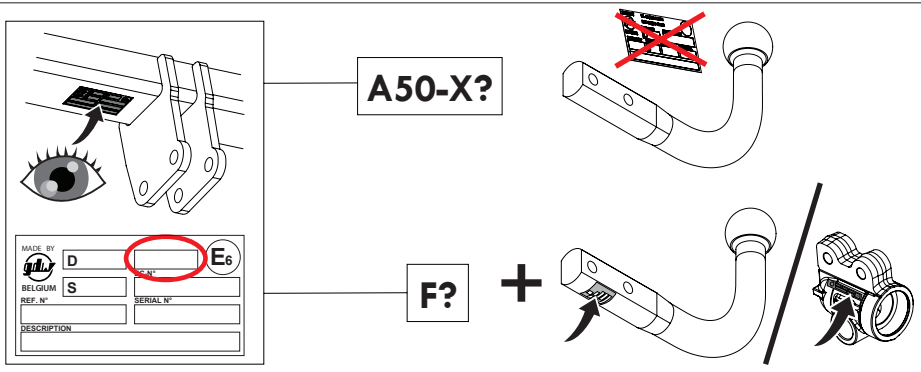
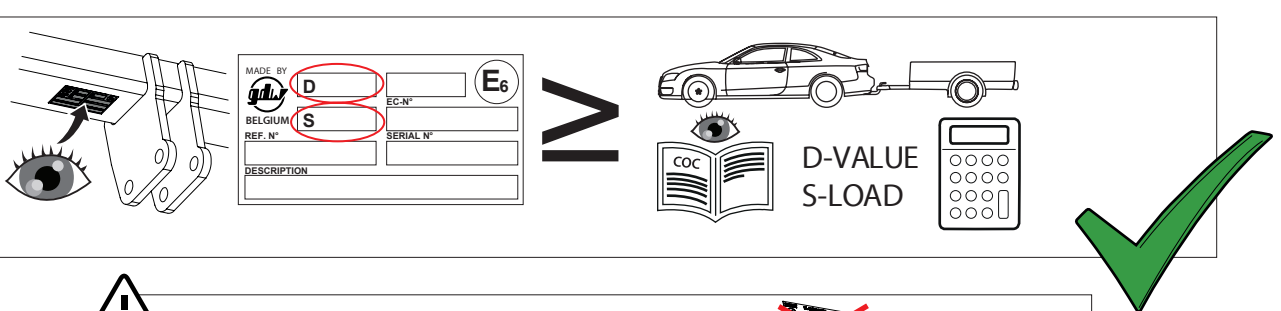
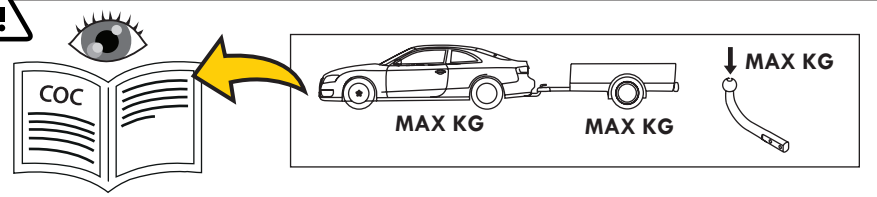

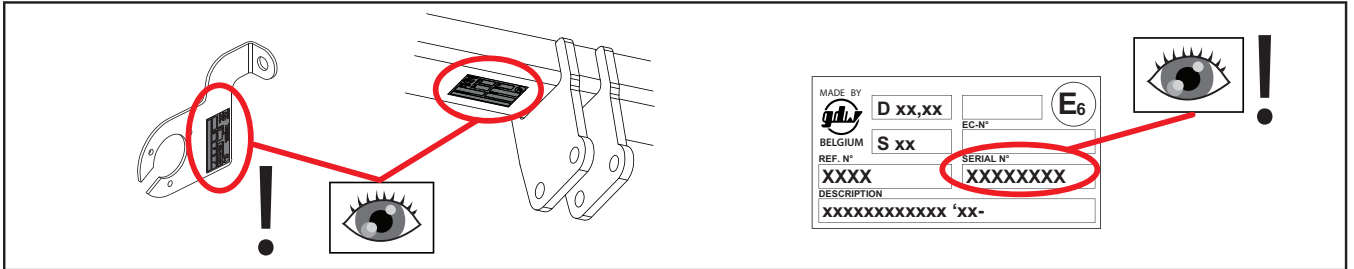





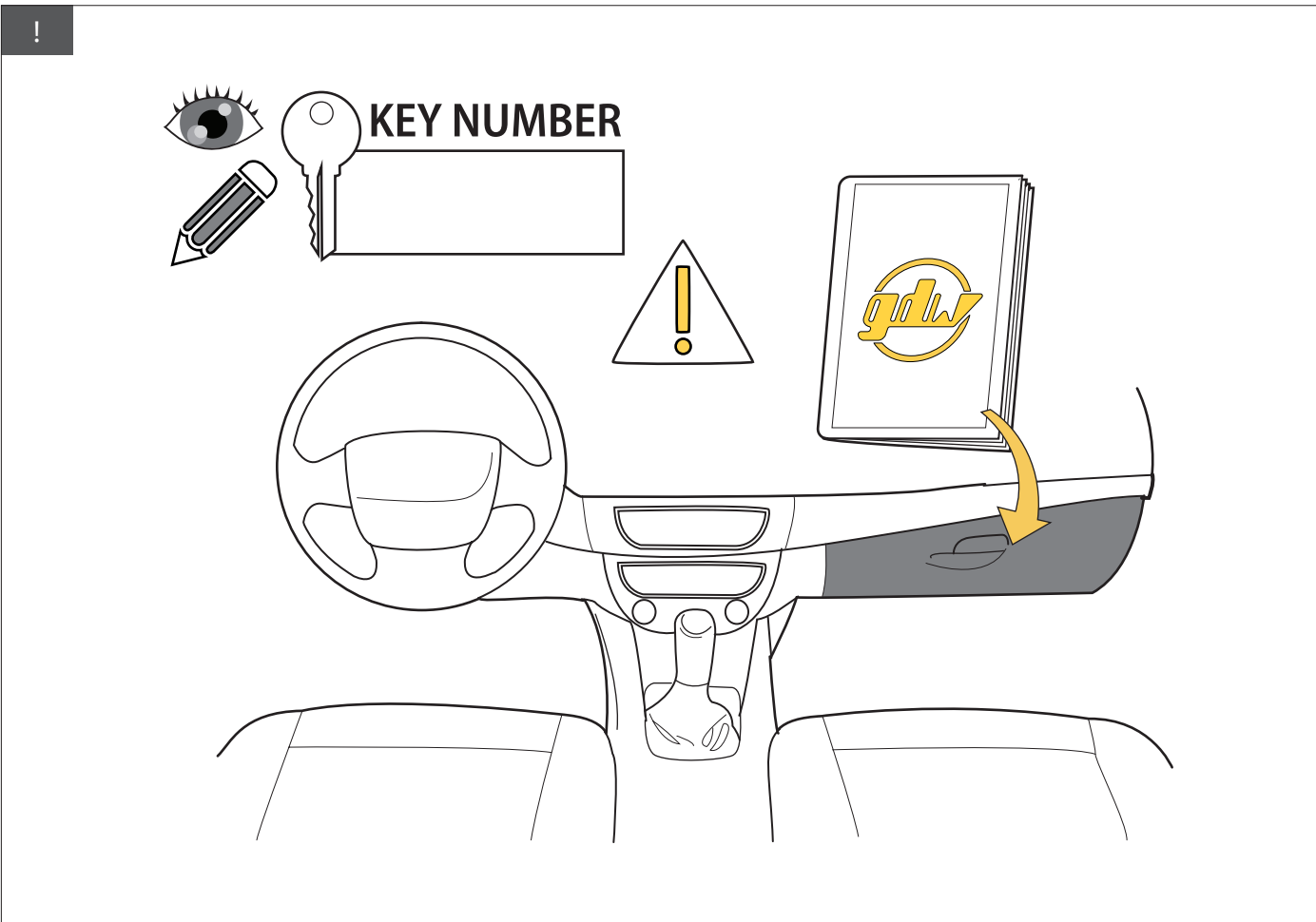

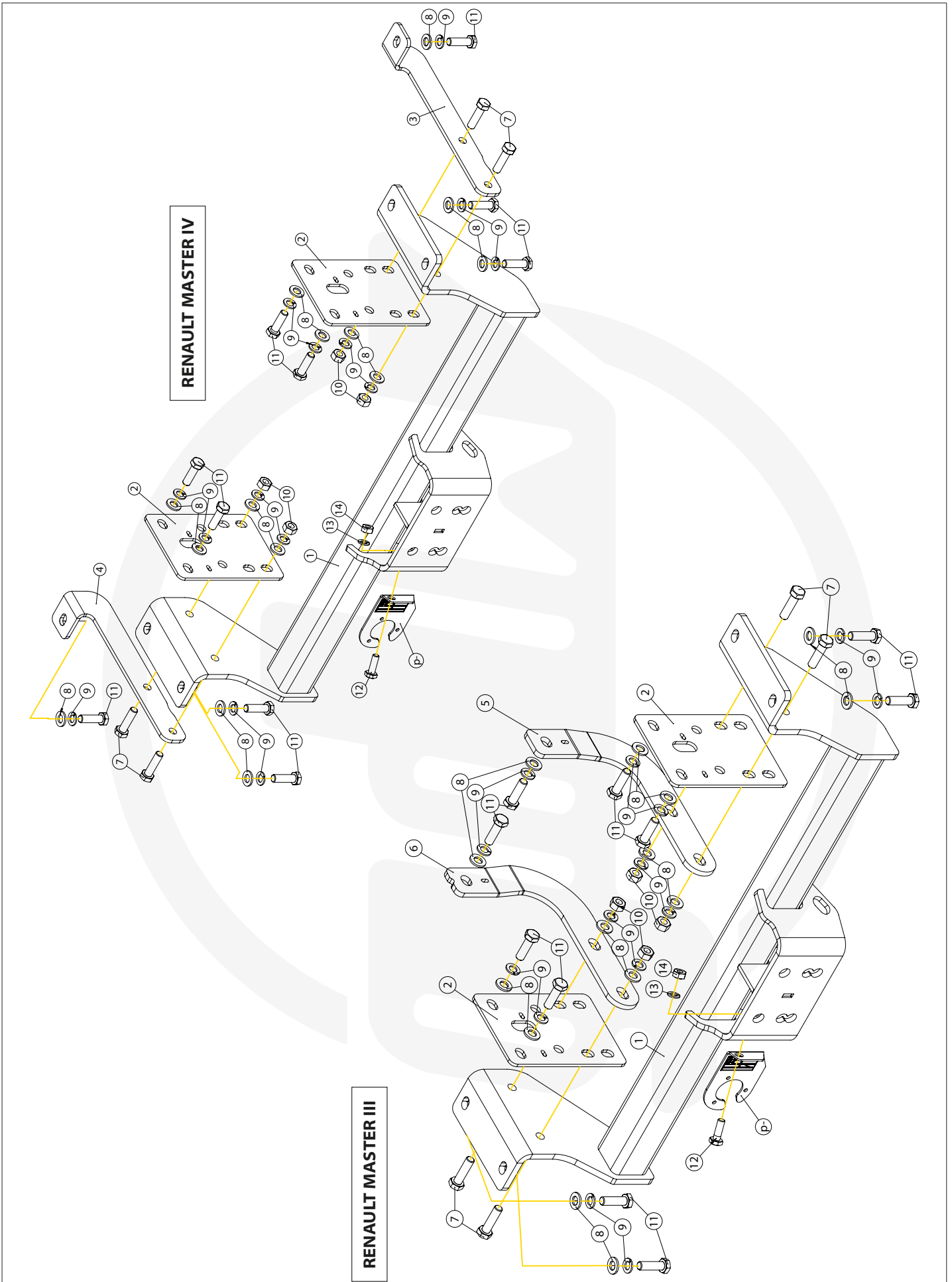

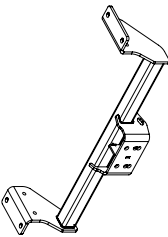
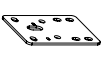



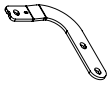





helpdesk@gdwtowbars.com
+32 56 62 77 79

Monday	08:00 - 12:00	12:30 - 16:30
Tuesday	08:00 - 12:00	12:30 - 16:30
Wednesday	08:00 - 12:00	12:30 - 16:30
Thursday	08:00 - 12:00	12:30 - 16:30
Friday	08:00 - 12:00	12:30 - 15:30



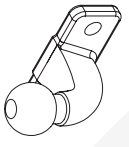

1		X1	GDW REF. 2866
2		X2	GDW REF. 2
3		X1	GDW REF. 3
4		X1	GDW REF. 4
5		X1	GDW REF. 5
6		X1	GDW REF. 6
7		X4	DIN 931-M 12X45
8		X14	DIN 125A-13X24X2.5
9		X14	GROWERVSK-M 12
10		X4	DIN 934-M 12
11		X10	DIN 933-M 12X40
12		X1	DIN 933-M 10X30
13		X1	GROWERVSK-M 10
14		X1	DIN 934-M 10
-P		X1	P 29

Geleverd met - Livré avec - Delivered with Geliefert mit - Elementos adjuntos - Leveres med - Forniti insieme		
	X1	GDW REF. 740.000
	X2	DIN128A-M 16
	X2	DIN933-M 16 X 50
	X2	DIN934-M 16

1

**RENAULT MASTER III
RENAULT MASTER IV**

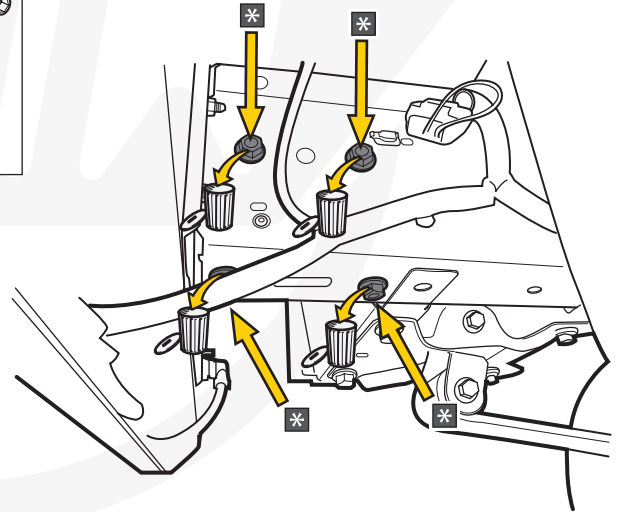
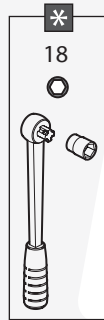
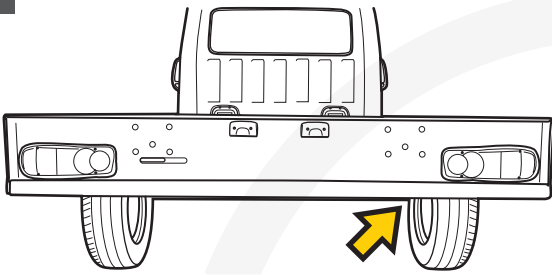

2

**RENAULT MASTER III
RENAULT MASTER IV**

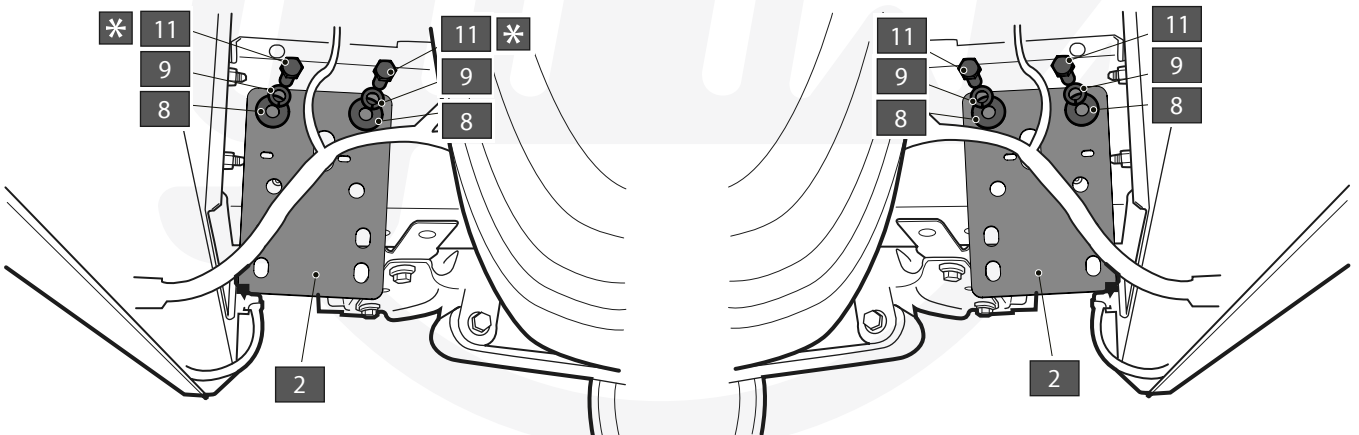
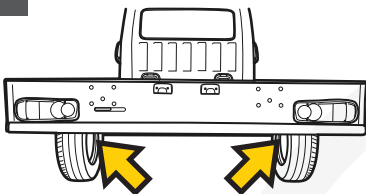

3

RENAULT MASTER IV

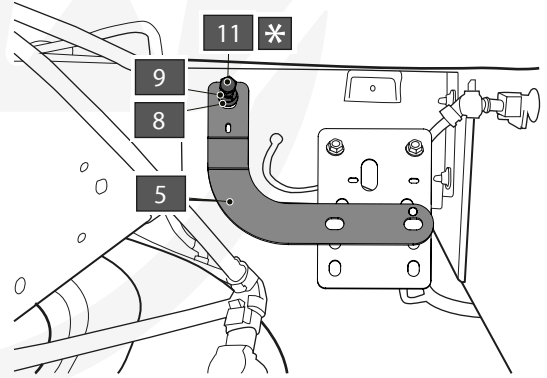
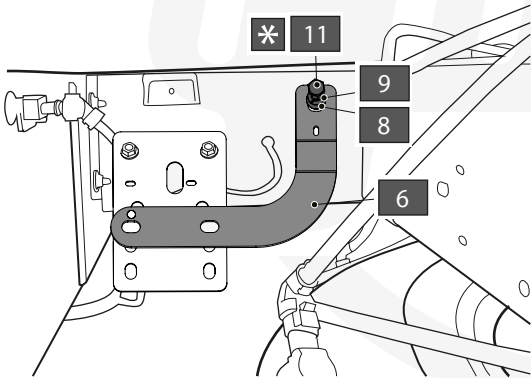
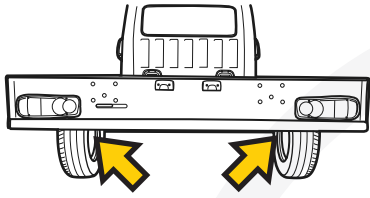

4

RENAULT MASTER III
RENAULT MASTER IV

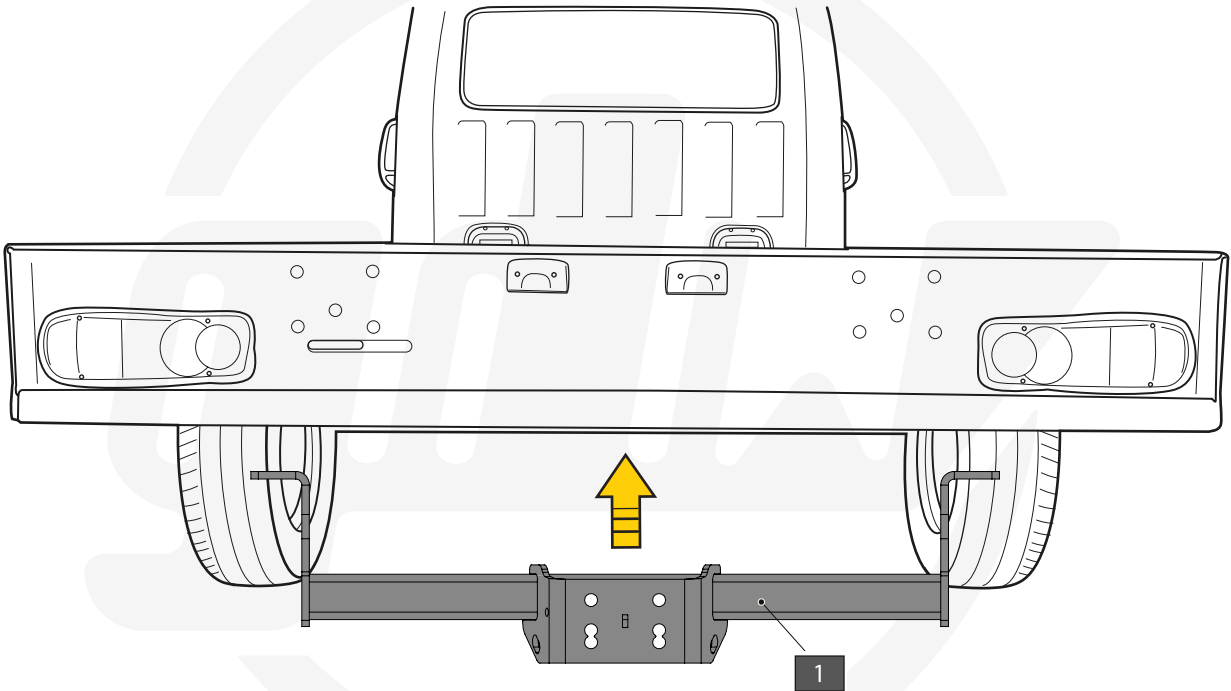

5

**RENAULT MASTER III
RENAULT MASTER IV**

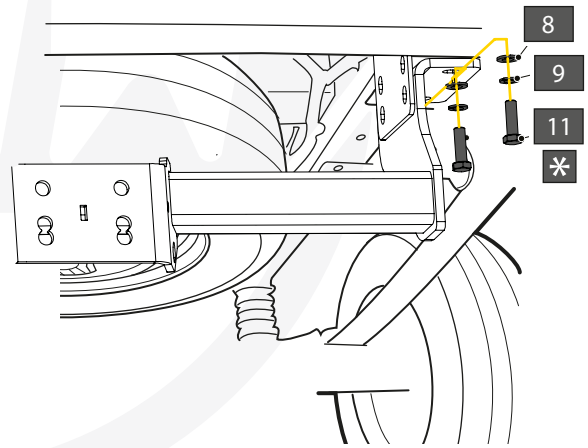
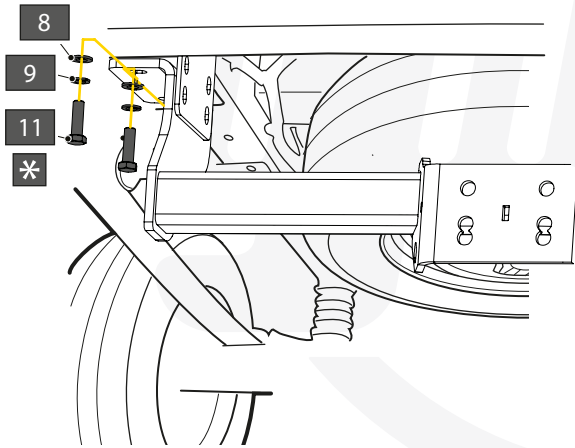
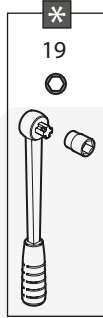
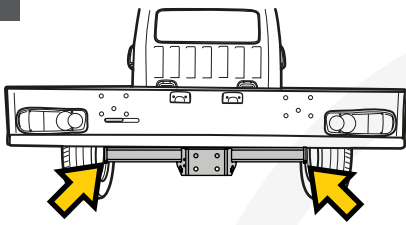

6

RENAULT MASTER III

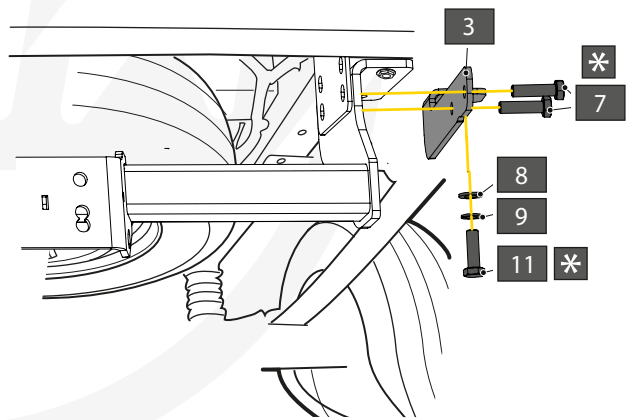
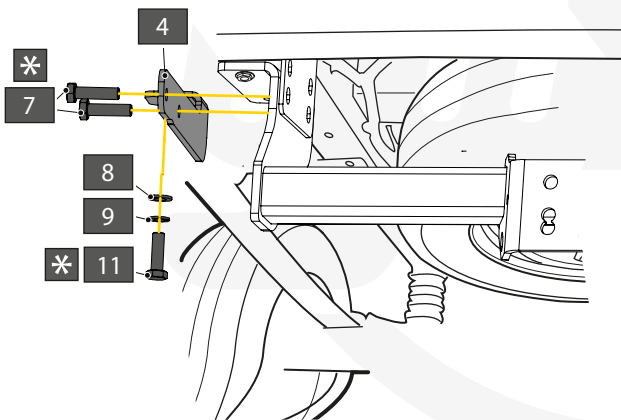
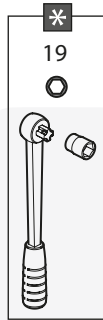
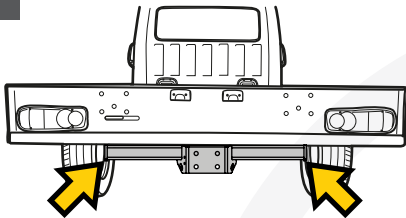

7

RENAULT MASTER IV

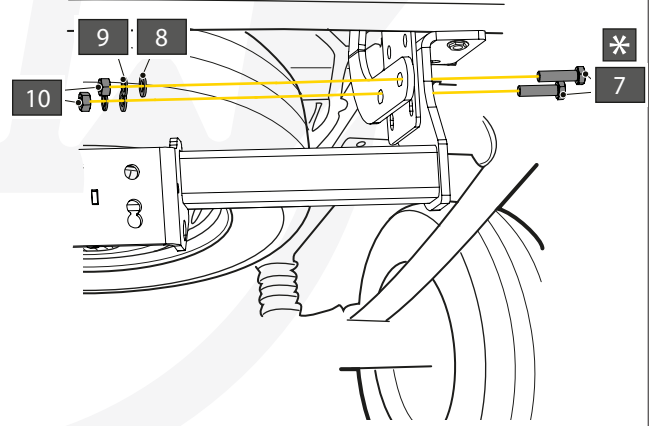
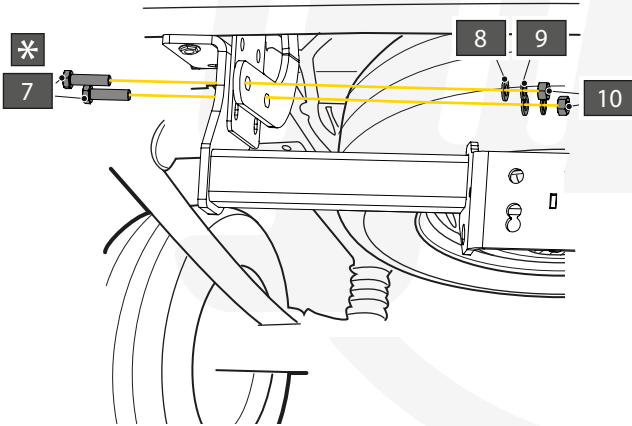
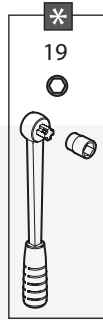
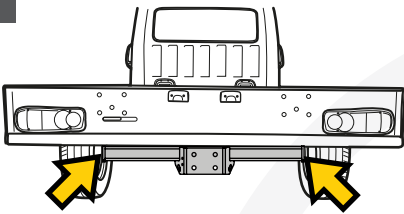

8

RENAULT MASTER III
 RENAULT MASTER IV

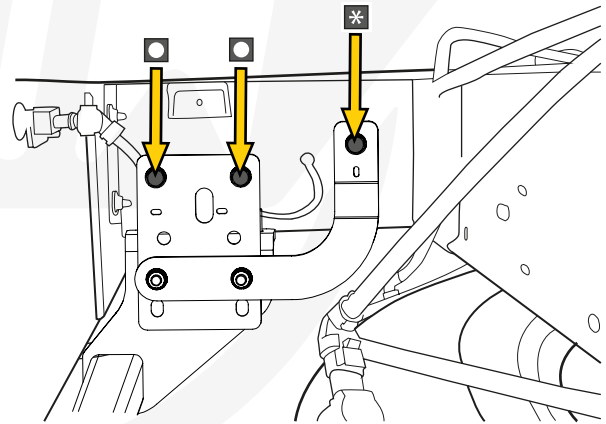
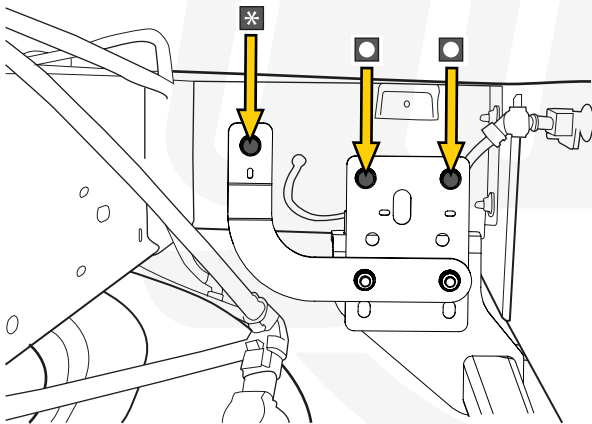
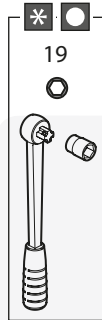
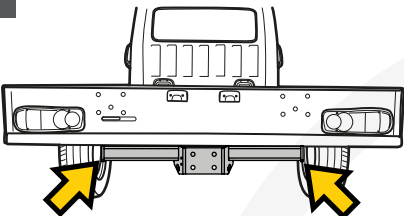

**RENAULT MASTER III
RENAULT MASTER IV**

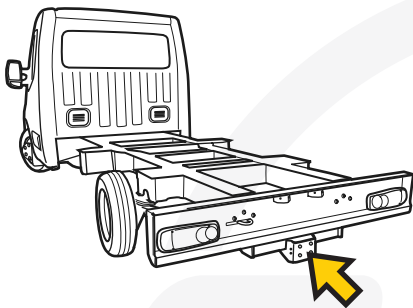
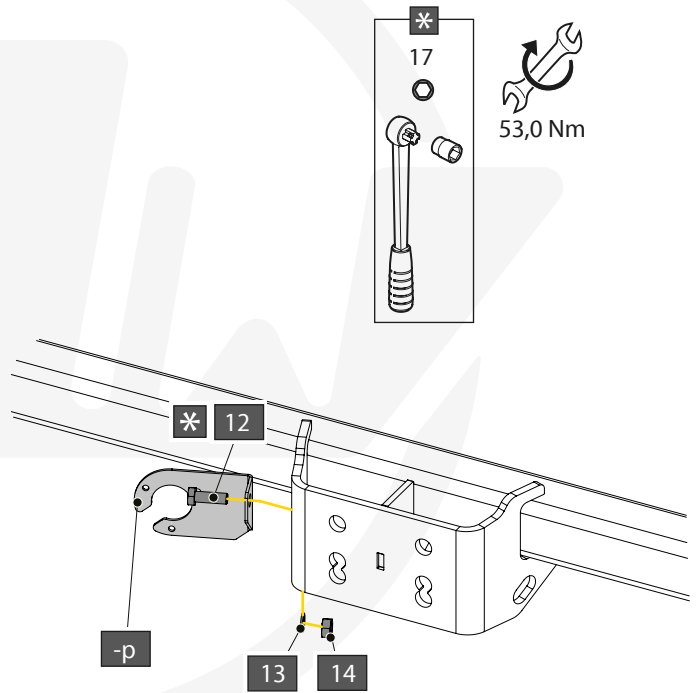
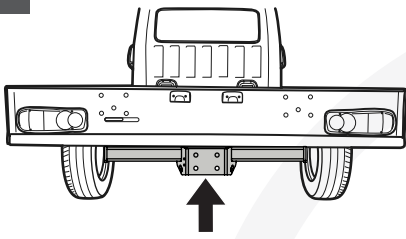

1

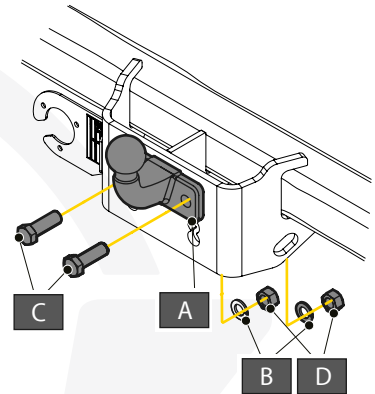

2

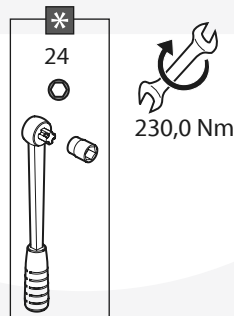
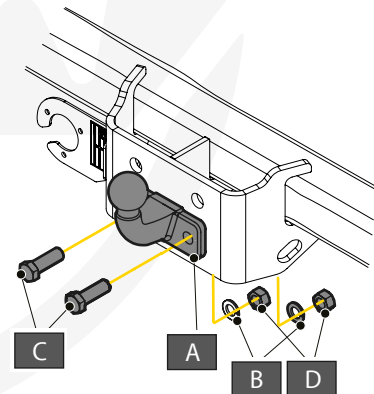

A		X1	740.000
B		X2	DIN128A-M 16
C		X2	DIN933-M 16 X 50
D		X2	DIN934-M 16

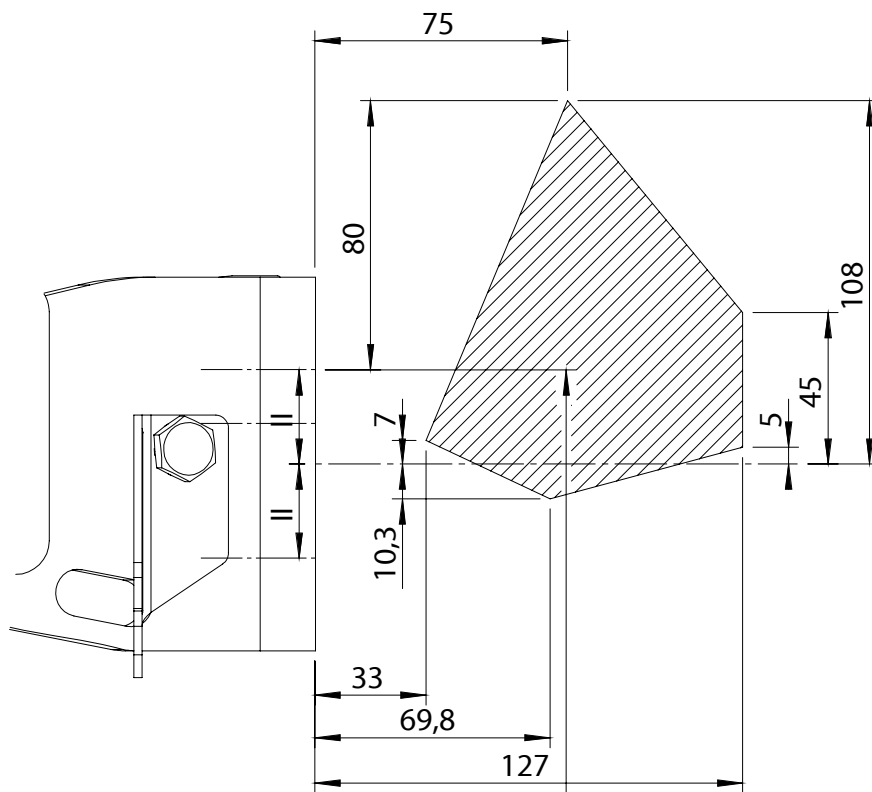

90x56mm
 gaten patroon
 Hole pattern
 Lochbild
 Schéma des trous

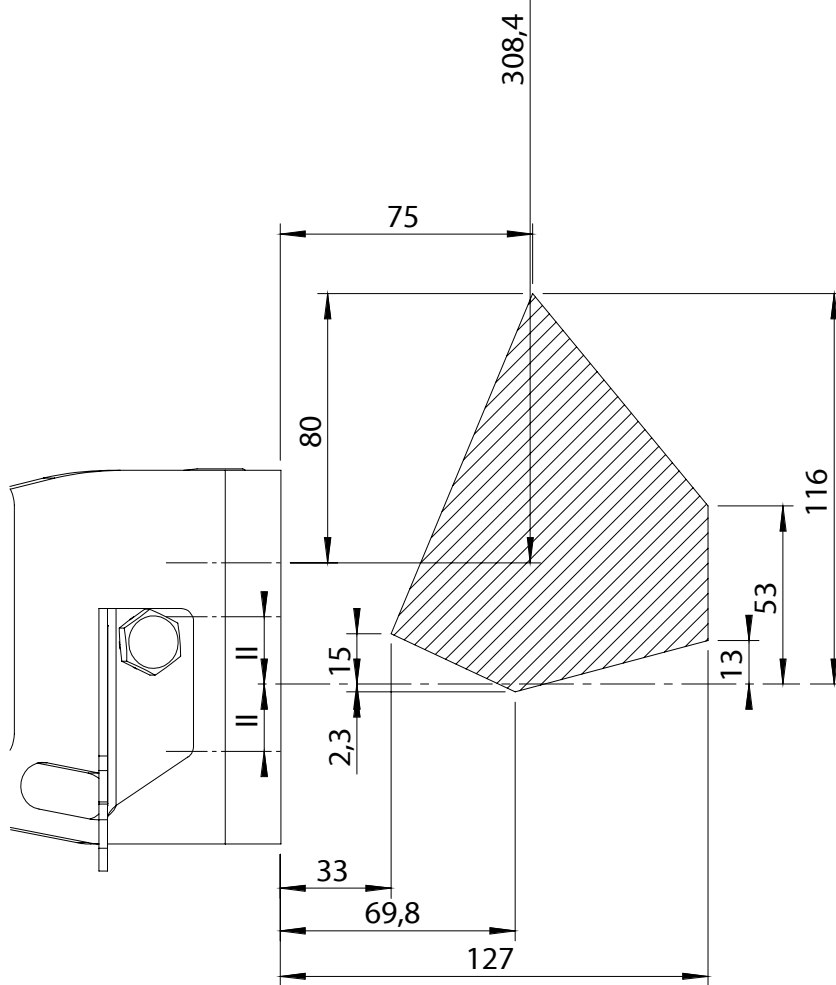

90x40mm
 gaten patroon
 Hole pattern
 Lochbild
 Schéma des trous

740.043

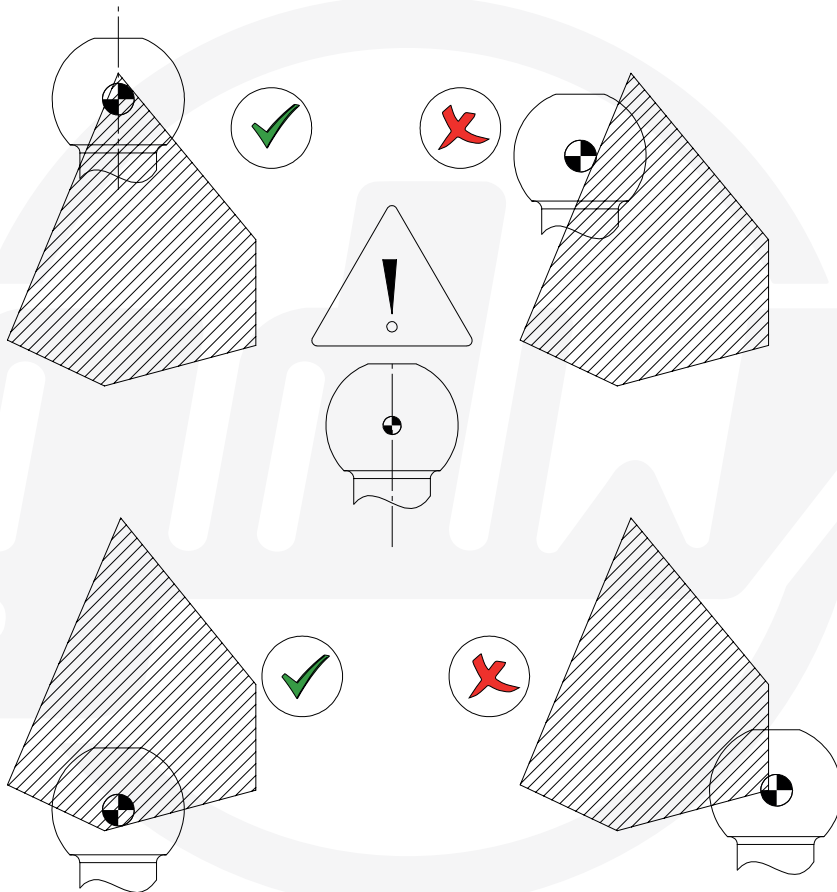
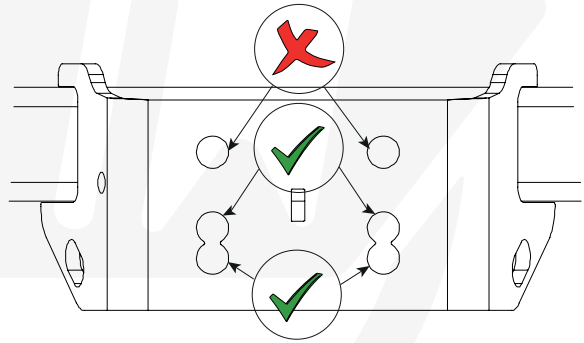
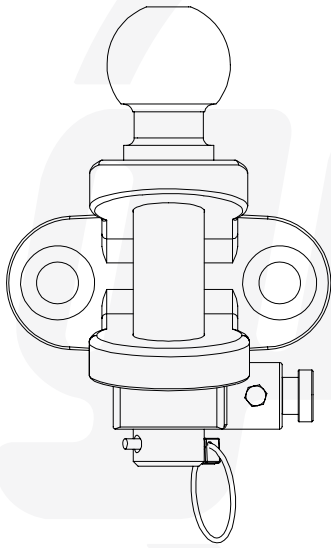

- 2 { Gate npatroom
Hole pattern
Lochbild
Schéma des trous

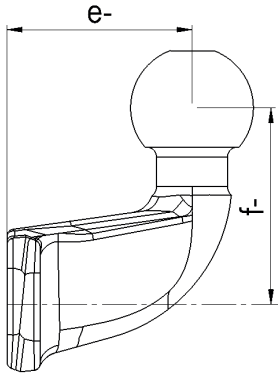

- 4 { Gate npatroom
Hole pattern
Lochbild
Schéma des trous

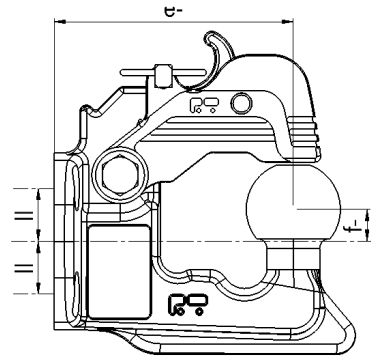

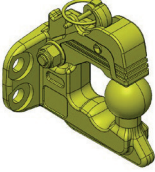
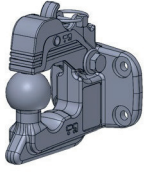
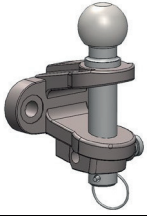
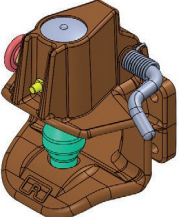
connection options		Gate npatroom, Hole pattern Lochbild, Schéma des trous	e- (mm)	f- (mm)
740.000		90mm	75	80
740.036		90x40mm	127	17
740.037		83x56mm + adapt 83x56	127	17
740.043		90mm	75	88.5
740.070		83x56mm + adapt 83x56	85	-0.5

DICHIARAZIONE DI CORRETTO MONTAGGIO

DECLARATION OF CORRECT INSTALLATION

La sottoscritta ditta dichiara di aver montato in maniera corretta il dispositivo di traino di cui sotto, seguendo le prescrizioni del costruttore del veicolo e del costruttore del dispositivo.

The undersigned company declares to have correctly mounted the towing device mentioned below, following the prescriptions of the vehicle manufacturer and the construction manufacturer.

COSTRUTTORE	<i>MANUFACTURER</i>	GDW N.V.
RIFERIMENTO	<i>REFERENCE</i>	2866
AUTOVEICOLO	<i>VEHICLE</i>	RENAULT MASTER III (X82) + MASTER IV (XDE), OPEL MOVANO (X62), NISSAN NV400 (X62) + INTERSTAR (X62, XDE)
CLASSE E TIPO DI ATTACO	<i>CLASS</i>	F
APPROVAZIONE	<i>HOMOLOGATION</i>	E6*55R02/02*1857
VALORE D	<i>D VALUE</i>	15,15 kN

Timbro e firma dell'installatore
Stamp & signature of installer

DATA
 DATE

MASSA RIMORCHIABILE	<i>TOWABLE MASS</i>	Vedere carta circolazione del veicolo <small>See registration certificate of vehicle</small>
CARICO VERTICALE MAX. S	<i>MAX. VERTICAL LOAD S</i>	115 kg

Per facilitare il controllo della compatibilità del dispositivo di traino sul veicolo, è opportuno confrontare le masse riportate sulla carta di circolazione del veicolo con le masse di riferimento sotto riportate (T ed C):
To simplify checking the compatibility of the towing device on the vehicle, it is advisable to compare the masses shown on the vehicle registration certificate with the reference masses shown below (T and C):

T = Massa complessiva del veicolo in kg *Total vehicle mass in kg*
 C = Massa rimorchiabile del veicolo in kg *Towable mass of the vehicle in kg*

Massa complessiva del veicolo, desunta dalla carta di circolazione (F2) in kg
Total mass of the vehicle, taken from the registration certificate (F2)
 deve essere inferiore od uguale a quella di riferimento T (= kg)
must be less than or equal to the reference T

Massa rimorchiabile del veicolo, desunta dalla carta di circolazione (O1) in kg
Towable mass of the vehicle, taken from the registration certificate (O1)
 deve essere inferiore od uguale a quella di riferimento C (= kg)
must be less than or equal to the reference C

Se tali condizioni sono verificate il dispositivo **è installabile**. *If these conditions are met, the device can be installed.*
 Se tali condizioni non si verificano, si deve procedere al seguente calcolo:
If these conditions are not met, the following calculation must be made:

$$D = \frac{T \times C}{T + C} \times 0,00981 = \dots\dots\dots \text{ kN}$$

Se D risulta inferiore a **15,15 kN** (valore riportato sulla targhetta e sul presente documento) il dispositivo **può essere installato**.
If D is less than 15,15 kN (value shown on the plate and on this document) the device can be installed.

NOTA ESPLICATIVA

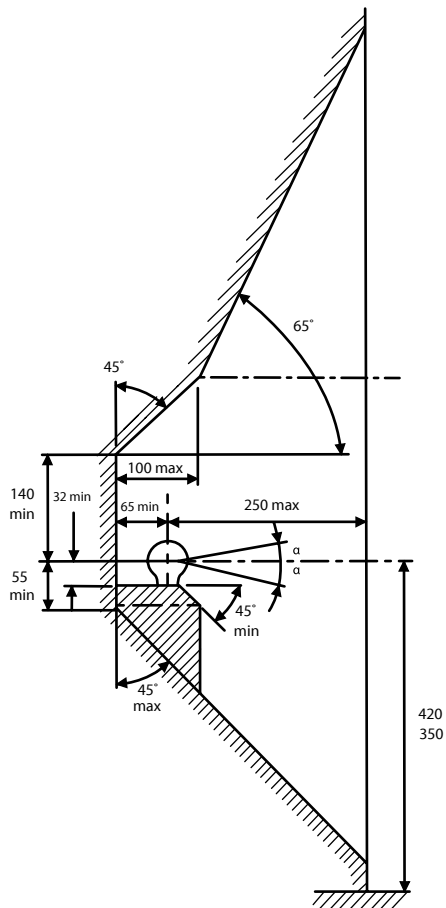

De tussenruimte conform bijlage VII, afbeelding 25 (a, b) van het reglement R55-01 UN/ECE moet in acht genomen worden. Deze voorschriften zijn niet van toepassing op terreinvoertuigen klasse G.

La zone de dégagement doit être garantie conformément à l'annexe VII, illustration 25 (a, b) de la règle R55-01 UN/ECE. Ces dispositions ne s'appliquent pas aux véhicules tout-terrain classe G.

The clearance specified in appendix VII, diagram 25 (a, b) of regulation R55-01 UN/ECE must be guaranteed. These requirements shall not apply to all-terrain vehicles class G.

Der Freiraum nach Anhang VII, Abbildung 25 (a, b) der Regulierung R55-01 UN/ECE ist zu gewährleisten. Diese Vorschriften gelten nicht für Geländefahrzeugen Klasse G.

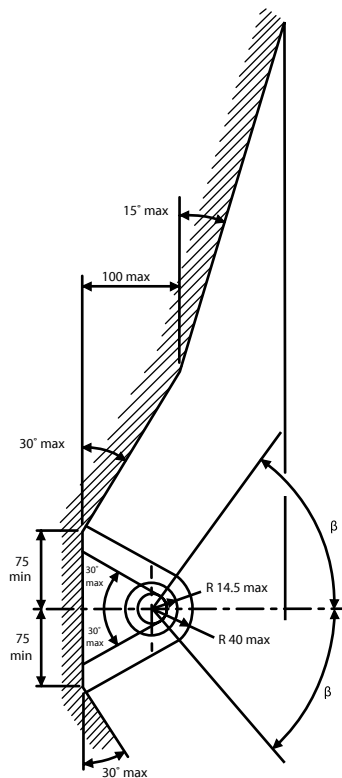

Bij toelaatbaar totaal gewicht van het voertuig

Pour poids total en charge autorisé du véhicule

At laden weight of the vehicle

Bei zulässigem Gesamtgewicht des Fahrzeuges

Peso total admisible del vehículo

Ved tilladt samlet vægt for køretøjet