



TREKHAKEN • ATTELAGES • ANHÄNGERVORRICHTUNGEN • TOWBARS • ENHANCES • ANHÆNGERTRÆK
Montagehandleiding | instructions de montage | Einbauanleitung | Mounting instruction
Instrucciones de montaje | monteringsvejledning



Peugeot Boxer 06/'06-

✓ STANDARD ✓ XL

Fiat Ducato 06/'06-

✓ STANDARD ✓ XL

Citroën Jumper 06/'06-

✓ STANDARD ✓ XL

Opel Movano 12/'21-

✓ STANDARD ✓ XL

Toyota ProAce Max 01/'24-

✓ STANDARD ✓ XL

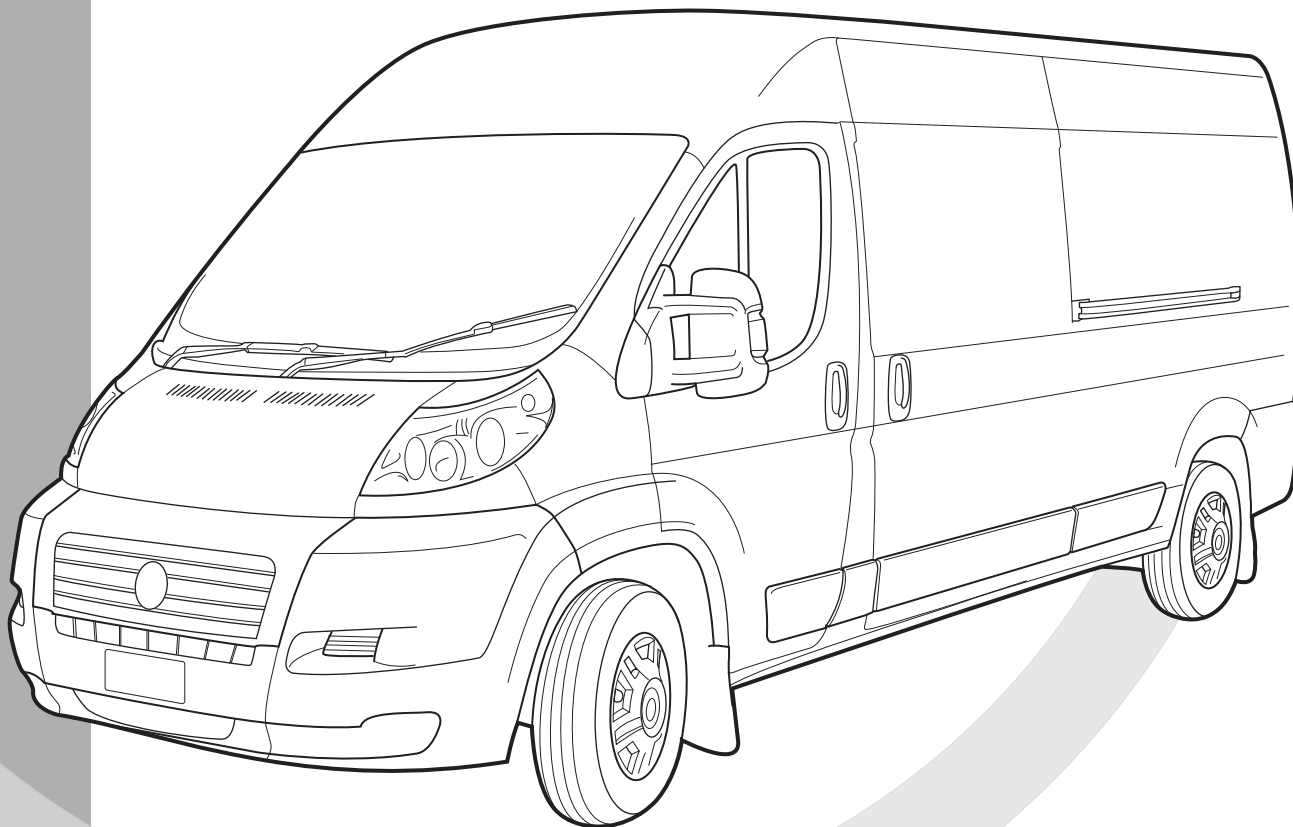

Montage

- Voor de montage moet de trekhaak eerst op het voertuig gepresenteerd worden.

De belasting van een aanhangwagen en van een accessoire dat op de koppelingskogel wordt voorzien, zijn anders van aard. Voor beiden kunnen verschillende limieten van toepassing zijn. Hiervoor verwijzen we naar het instructieboekje van de wagen of naar uw concessiehouder.

Montage

- Présenter l'attelage sous le véhicule avant d'effectuer le montage.

La charge d'une remorque ou d'un accessoire monté sur la boule d'attelage, sont de nature différentes. Des limites différentes peuvent s'appliquer à l'un et à l'autre. Nous vous recommandons de vous référer à votre livret d'instructions ou de vous renseigner chez votre concessionnaire.

Fitting

- Present the towbar under the car first to check if all points are right.

The load of a trailer and of an accessory fitted on the towing ball are of a different nature. Different limits may apply to both. For this matter, we refer to the instruction manual of the vehicle or we advise you to contact your concessionaire.

Montage

- Halten Sie die Anhängerkupplung zunächst unter das Fahrzeug und prüfen Sie, ob alle Punkte übereinstimmen.

Die Last eines Anhängers und die Last eines an der Zugkugel montierten Zubehörs unterscheiden sich grundsätzlich. Für beide können unterschiedliche Grenzwerte gelten. Wir verweisen diesbezüglich auf die Betriebsanleitung des Fahrzeugs oder empfehlen Ihnen, sich an Ihren Vertragshändler zu wenden.

Montaje

- Presentar el enganche debajo del vehículo antes de realizar el montaje.

La carga de un remolque y un accesorio montado en una bola de remolque son de una naturaleza diferente. Se pueden aplicar diferentes límites a ambos. Para este asunto, nos referimos al manual de instrucciones del vehículo o le recomendamos que contacte a su distribuidor.

Montering

- Præsenter trækstangen under bilen først for at kontrollere, om alle punkter er rigtige.

Belastningen af en trailer og af tilbehør tilkoblet anhængertrækket er forskellige. Der kan være forskellige begrænsninger på begge. I disse tilfælde henviser vi til bilens manual, eller anbefaler dig at kontakte bilforhandleren

Montaggio

- In primo luogo, presentare la struttura sotto l'automobile per verificare che tutti i punti di attacco coincidano.

La massa rimorchiabile del veicolo potrebbe essere diversa dal valore riportato sul documento del gancio di traino. Per questo motivo, vi invitiamo a consultare sempre la carta di circolazione del veicolo (Pos. O.1) o a rivolgervi alla vostro concessionario di fiducia

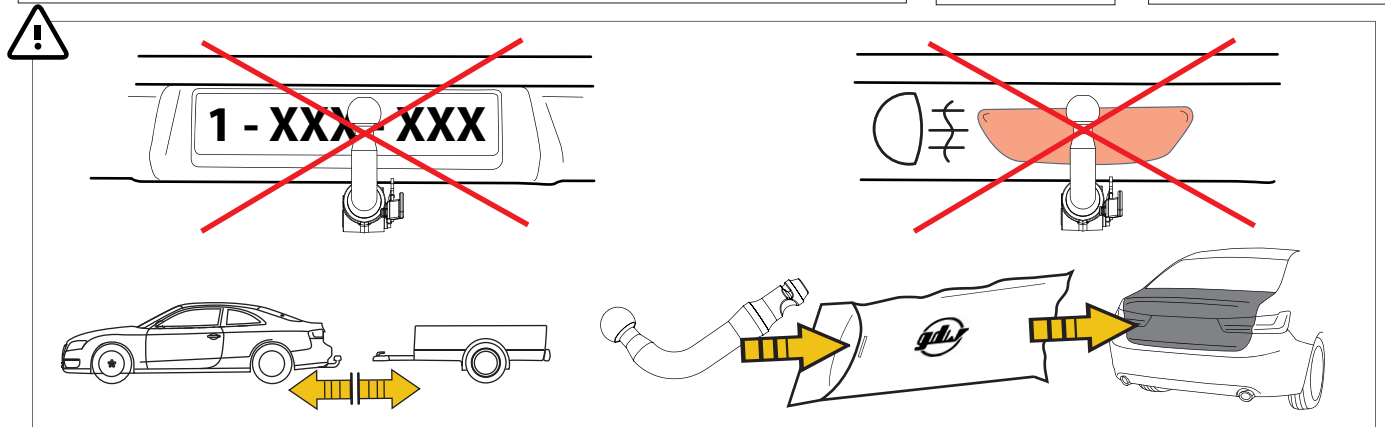
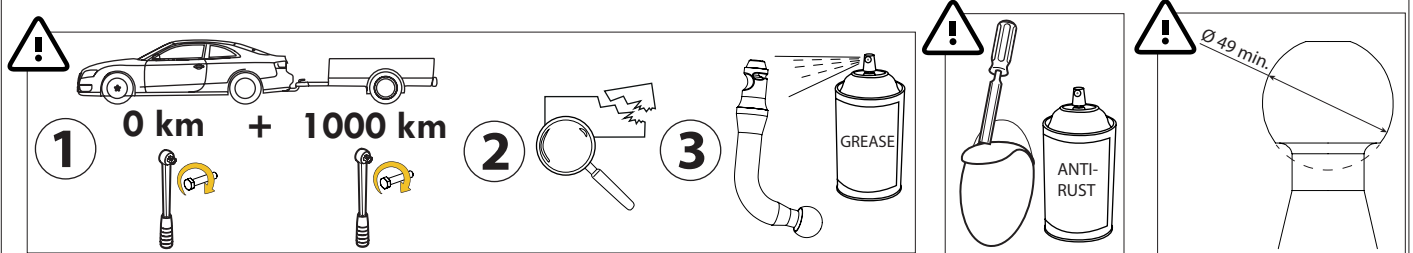
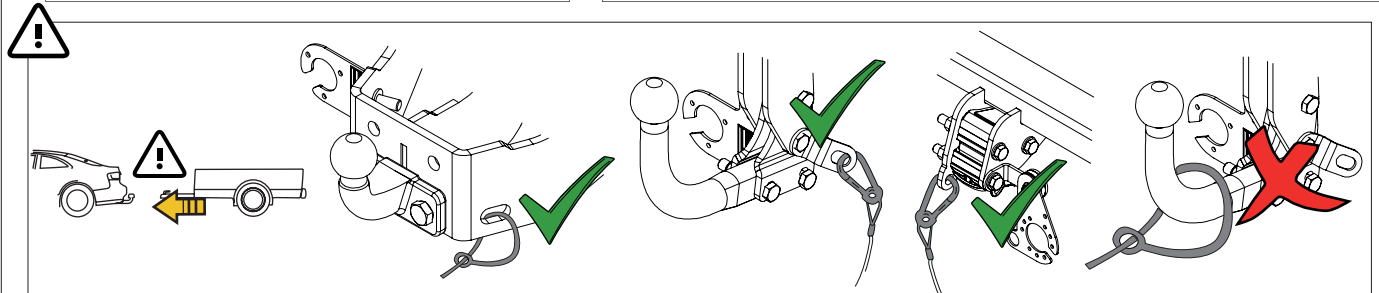
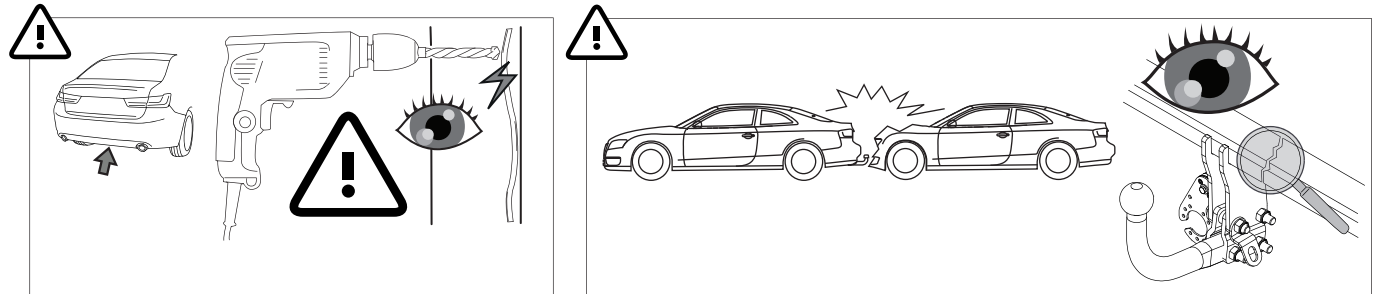
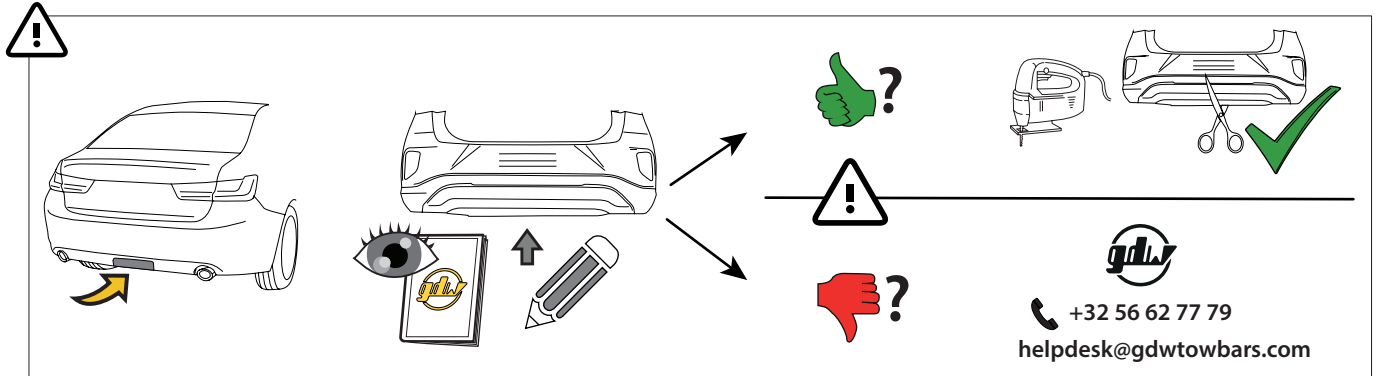
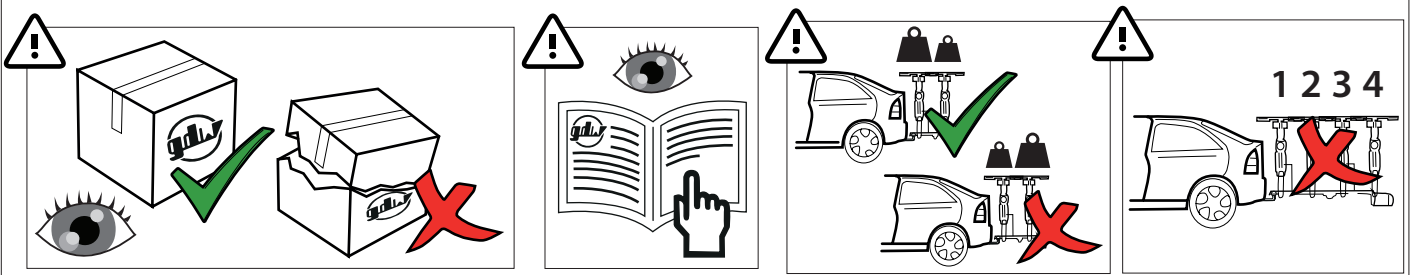

MADE BY



D 15,85

F

EC-N°



BELGIUM

S 150

55R- 01 1303

REF N°

2144

SERIAL N°

XXXX

DESCRIPTION

Fiat Ducato, Citroën Jumper, Peugeot Boxer '06-, Opel Movano '21-, Toyota ProAce Max '24-



$$D = \frac{\text{max kg (car)} \times \text{max kg (trailer)}}{\text{max kg (car)} + \text{max kg (trailer)}} \times 0.00981 \leq 15,85 \text{ kN}$$

$$S = \begin{matrix} \downarrow \\ \leq 150 \text{ kg} \end{matrix} + \begin{matrix} \downarrow \\ \leq 3000 \text{ kg} \end{matrix}$$



See the Certificate Of Conformity (COC) of your vehicle or contact your dealer to verify the max. trailer weight of your car!



See the user manual of the vehicle for correct use of bicycle carriers!

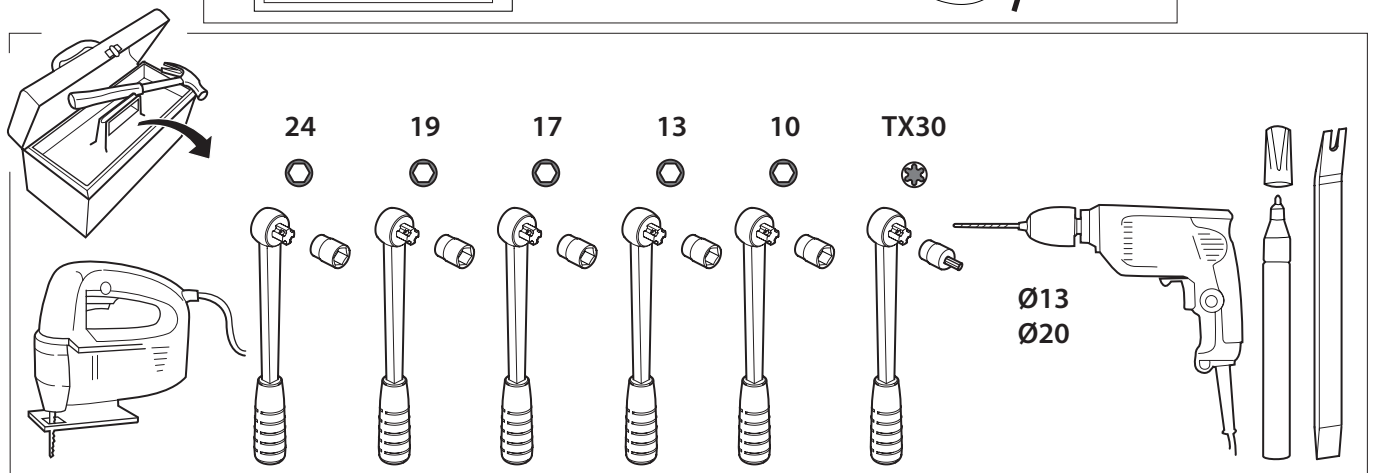
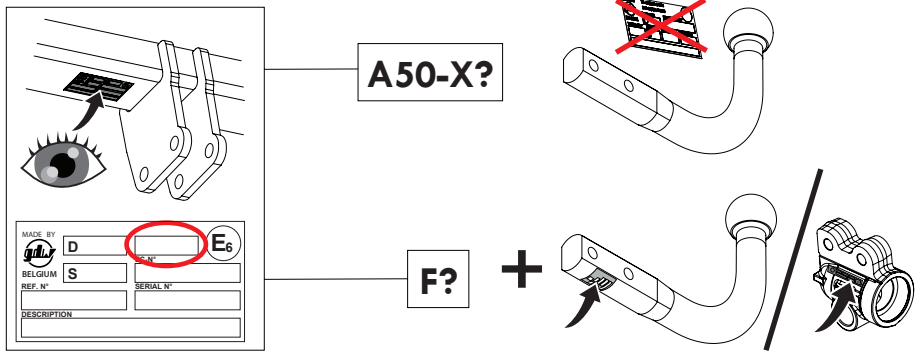
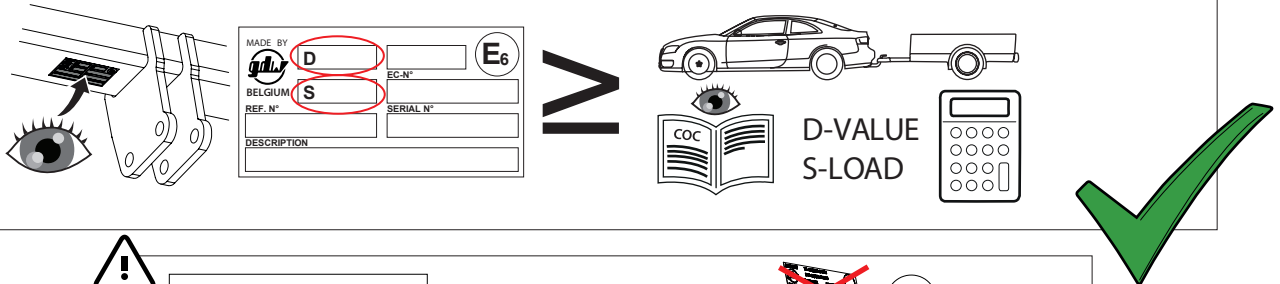
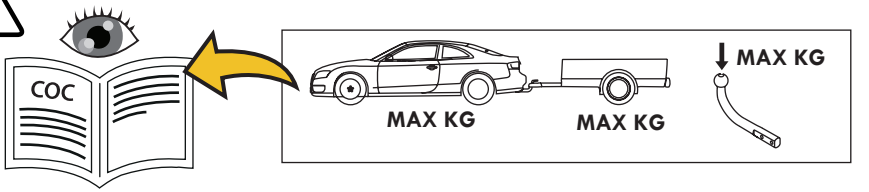

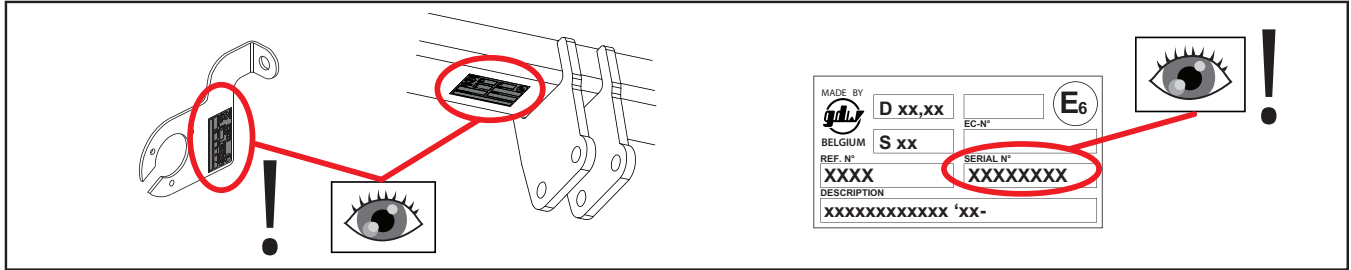





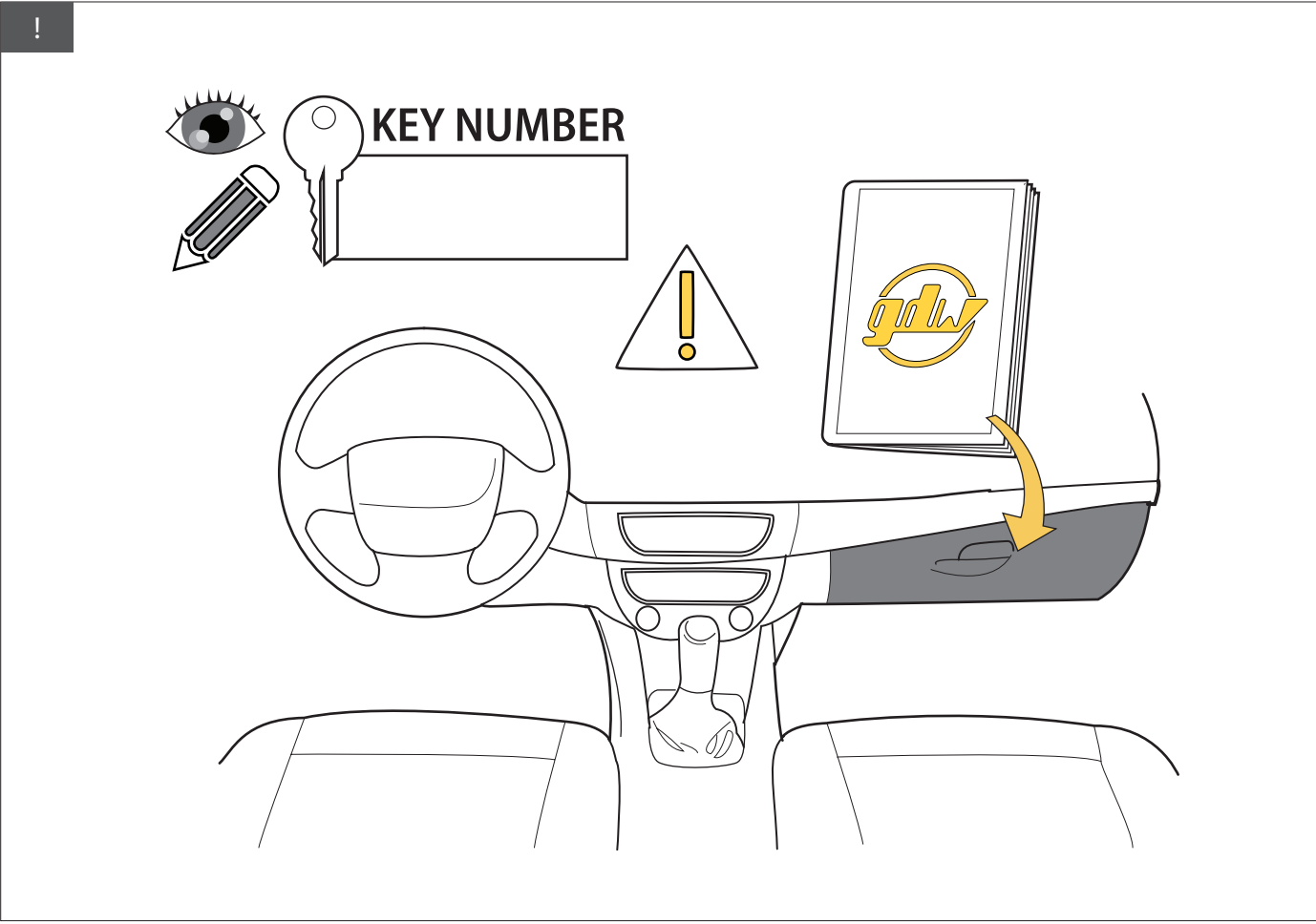

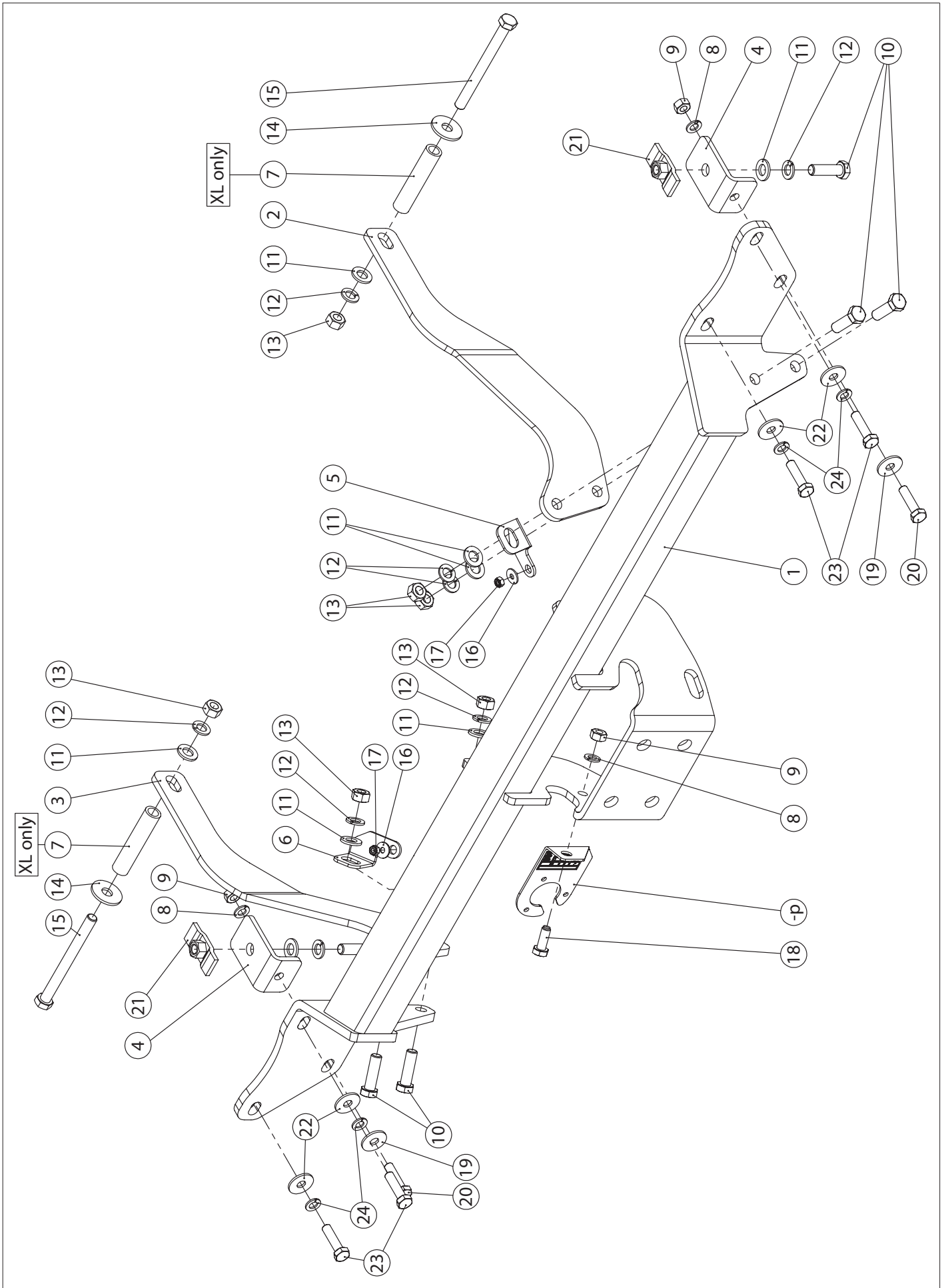

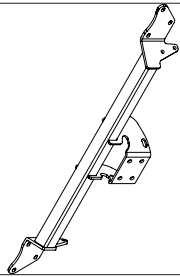



















helpdesk@gdwtowbars.com
+32 56 62 77 79

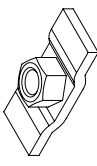





Monday	08:00 - 12:00	12:30 - 16:30
Tuesday	08:00 - 12:00	12:30 - 16:30
Wednesday	08:00 - 12:00	12:30 - 16:30
Thursday	08:00 - 12:00	12:30 - 16:30
Friday	08:00 - 12:00	12:30 - 15:30



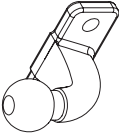

1		X1	GDW REF. 2144	
2		X1	GDW REF. 2	
3		X1	GDW REF. 3	
4		X2	GDW REF. 4	
5		X1	GDW REF. 5	
6		X1	GDW REF. 6	
7		X2	GDW REF. 7 ONLY XL	
8		X3	DIN 128A-M10	
9		X3	DIN 934-M10 - 1.25	
10		X6	DIN 931-M12X45	
11		X8	DIN125-A12-140HV- ELVZ	
12		X8	DIN 128A-M12	
13		X6	DIN 934-M12	
14		X2	DIN9021-M12-ELVZ	
15		X2	DIN931-M12X130	
16		X2	DIN9021-M6-ELVZ	
17		X2	DIN985-M6	
18		X1	DIN 961-M10X25 - 1.25	

19		X2	DIN9021-M10-ELVZ	
20		X2	DIN 961-M10X40 - 1.25	
21		X2	GDW REF. 902.004	
-P		X1	GDW REF. P29	
CHASSIS N° ≤ 1067810				
22		X4	DIN9021-M8-ELVZ	
23		X4	DIN 933-M8X40	
24		X4	DIN 128A-M8	
CHASSIS N° ≥ 1067811				
22		X4	DIN9021-M10-ELVZ	
23		X4	DIN 961-M10X40 - 1.25	
24		X4	DIN 128A-M10	

Geleverd met - Livré avec - Delivered with Gefiefert mit - Elementos adjuntos-Leveres med			
	X1	740.000	
	X2	DIN128A-M16	
	X2	DIN933-M16 X 50	
	X2	DIN934-M16	
	X4	KABELBINDER 160X2,5	
	X4	BIND. SOK 28	

1

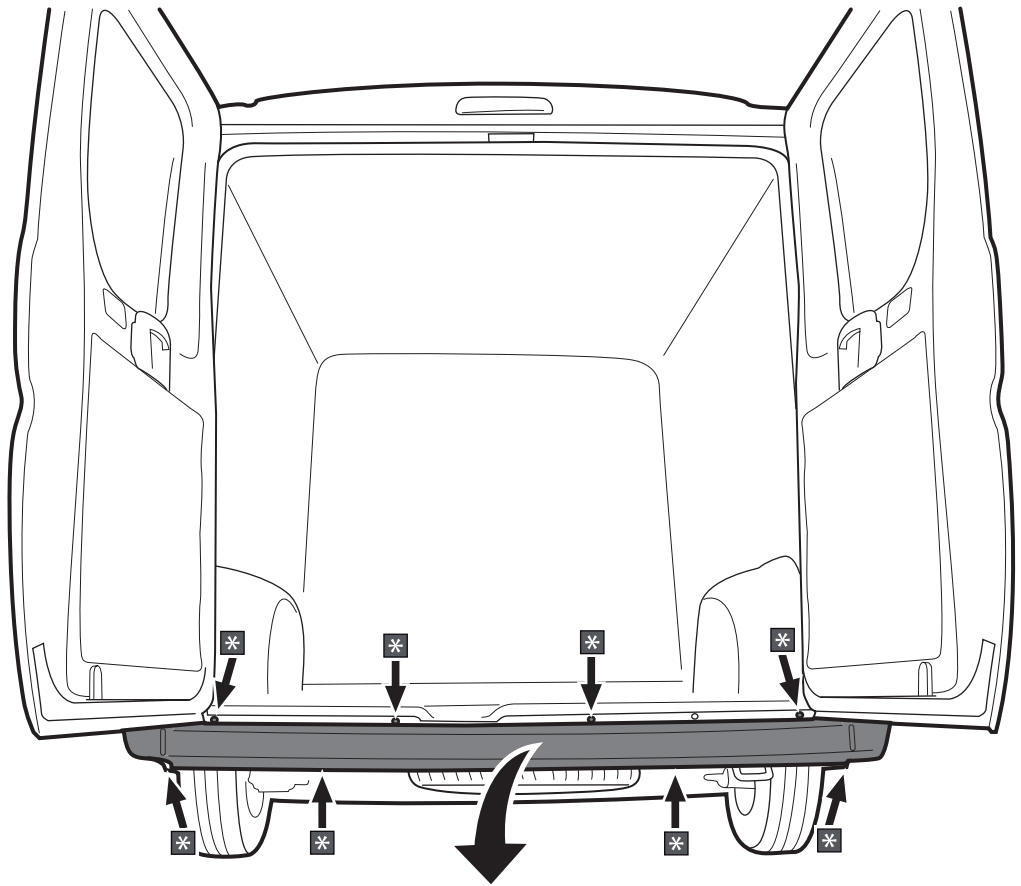
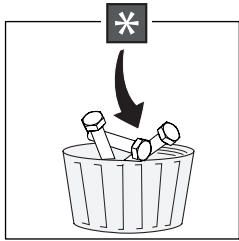
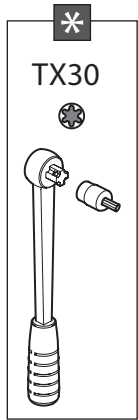

2

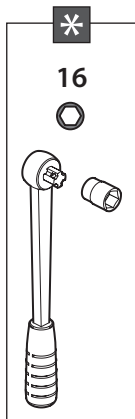

**SMART KEY
SENSOR:
ORDER 650.040**

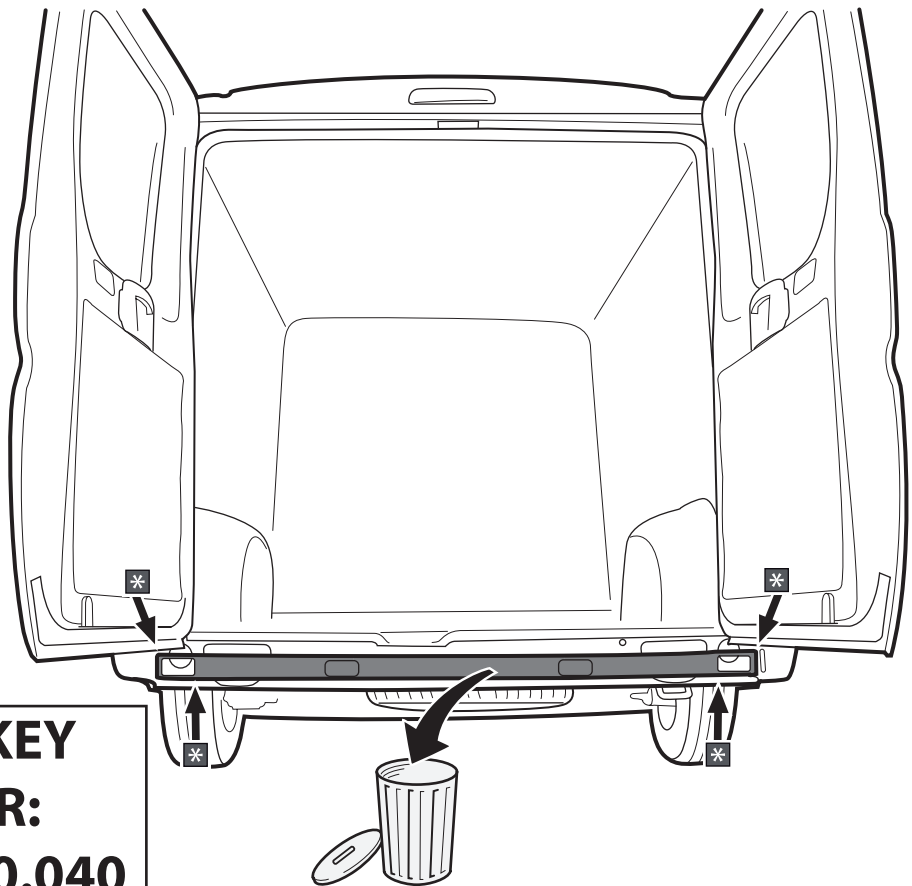

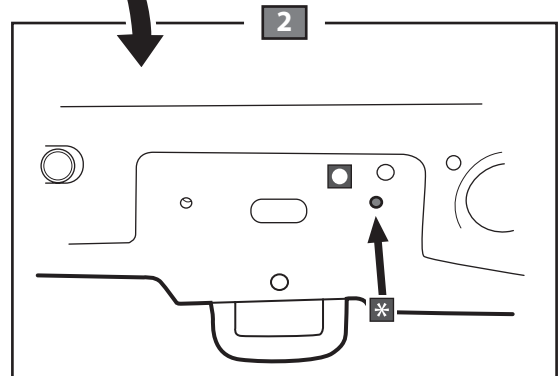
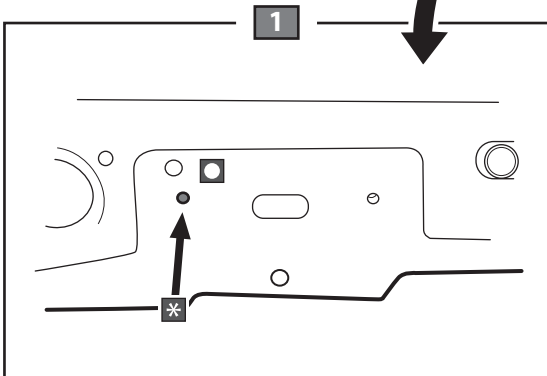
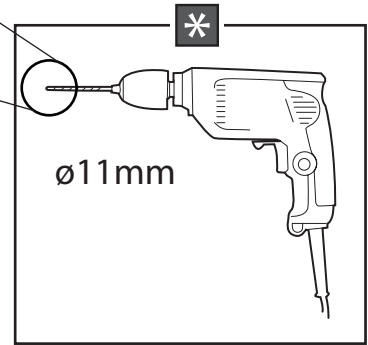
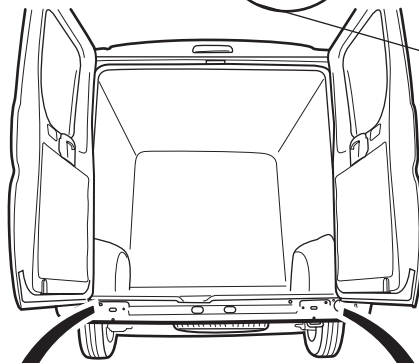
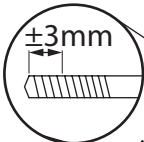
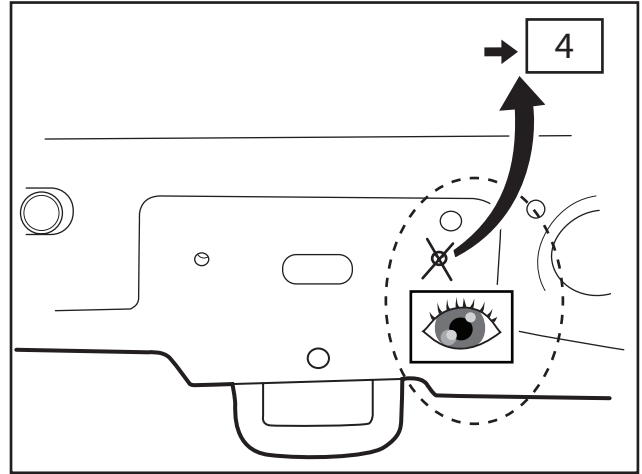
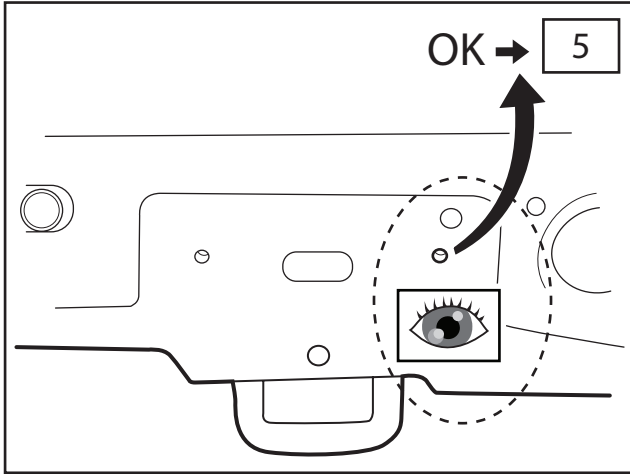
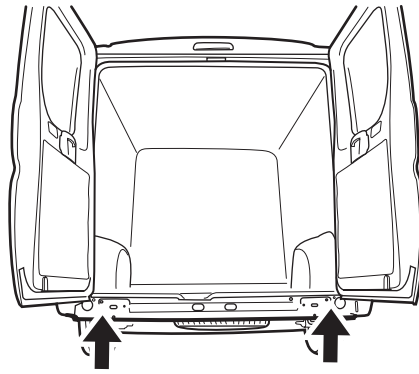

5

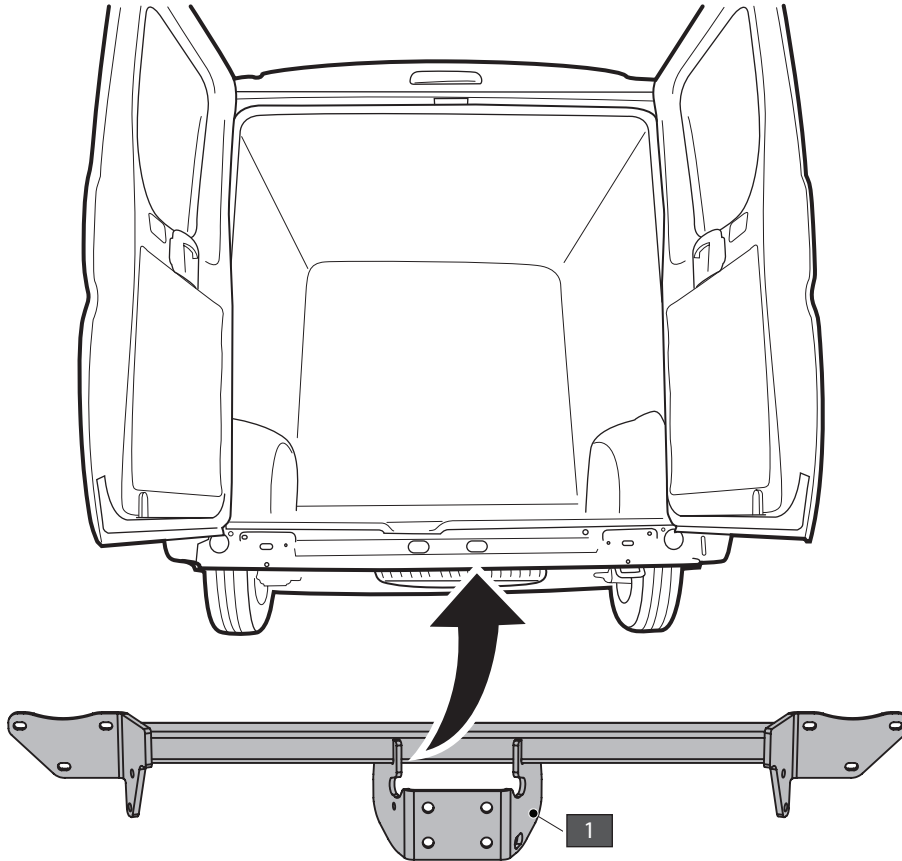

6



Chassis n° ≥ 1067811 M10x40x1.25 DIN 961
 Chassis n° ≤ 1067810 M8x40 DIN 933

Chassis n° ≥ 1067811

Chassis n° ≤ 1067810



17

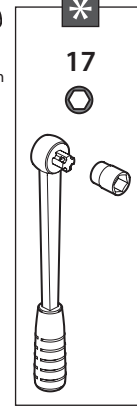

13

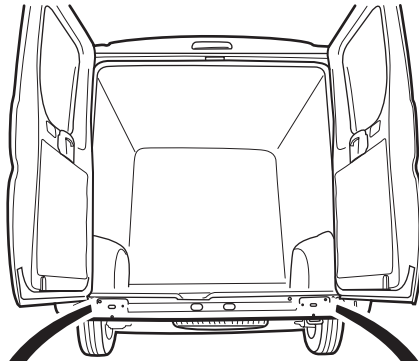
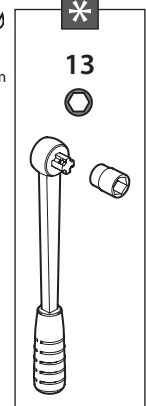

1

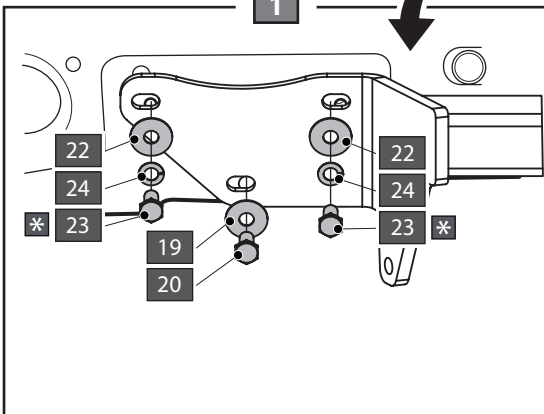

2

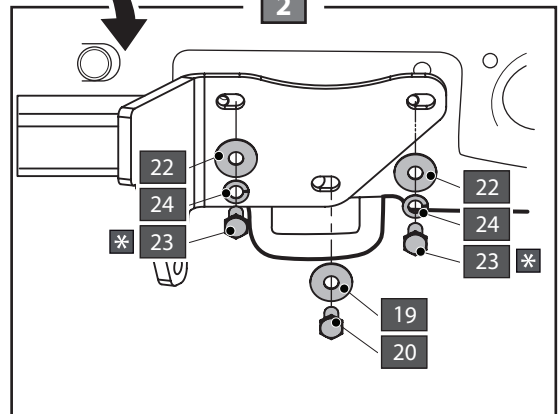

7

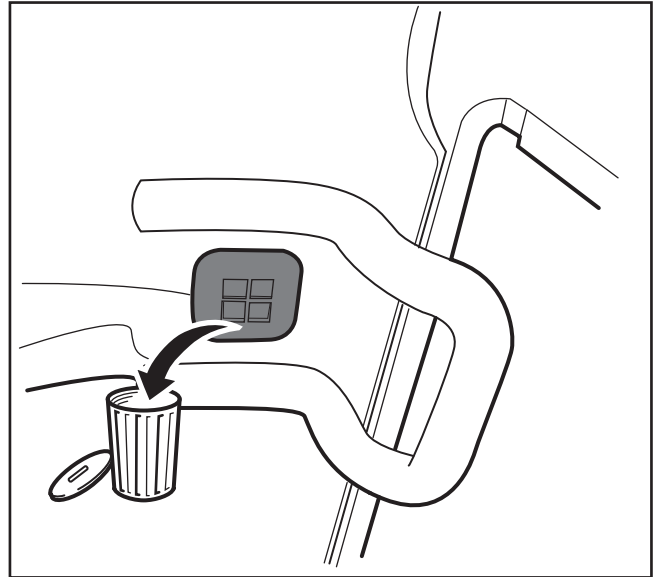
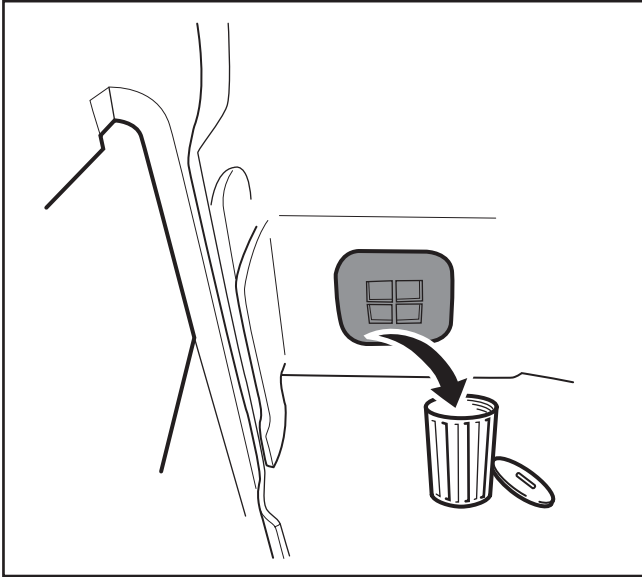
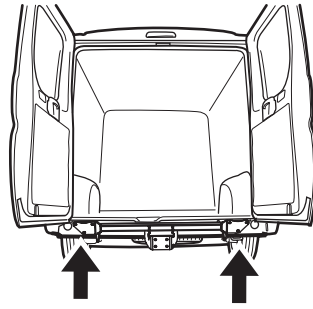

8

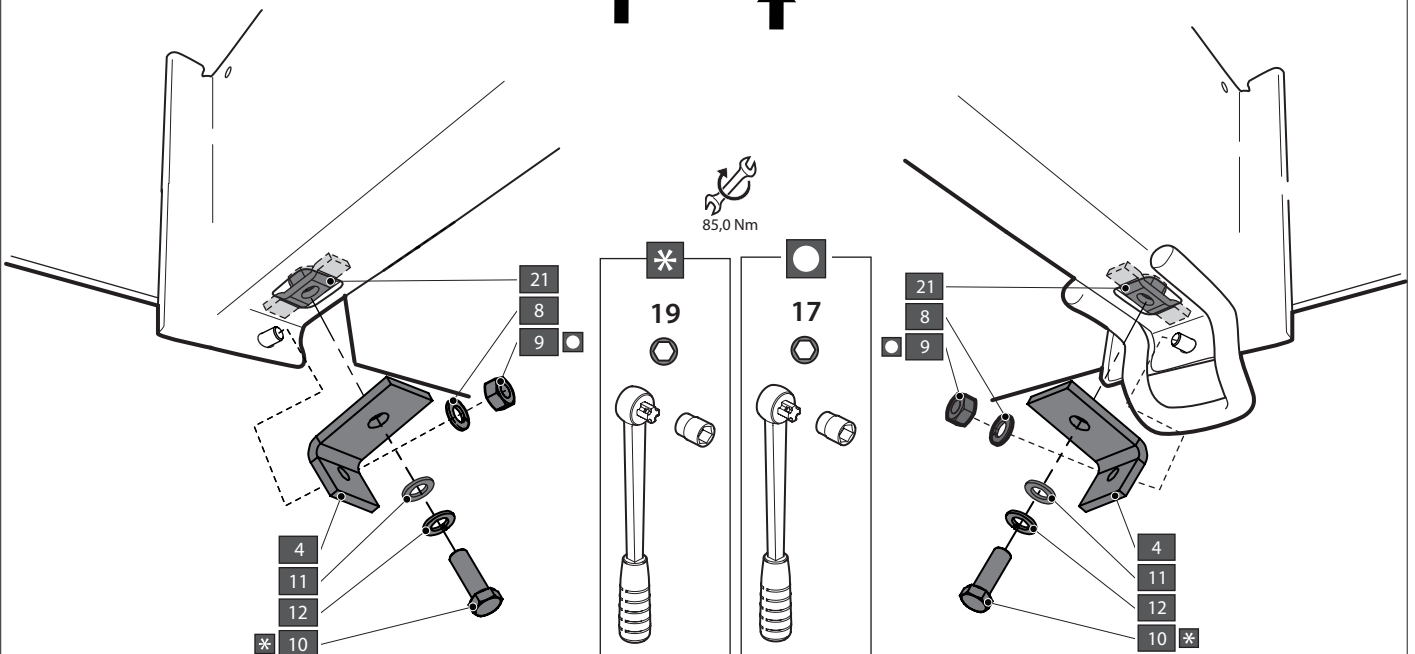
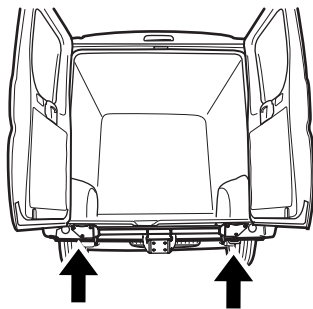

9

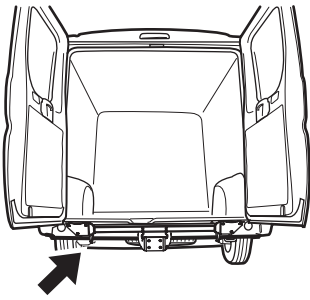

15

Fiat Ducato IV '06 **XL**

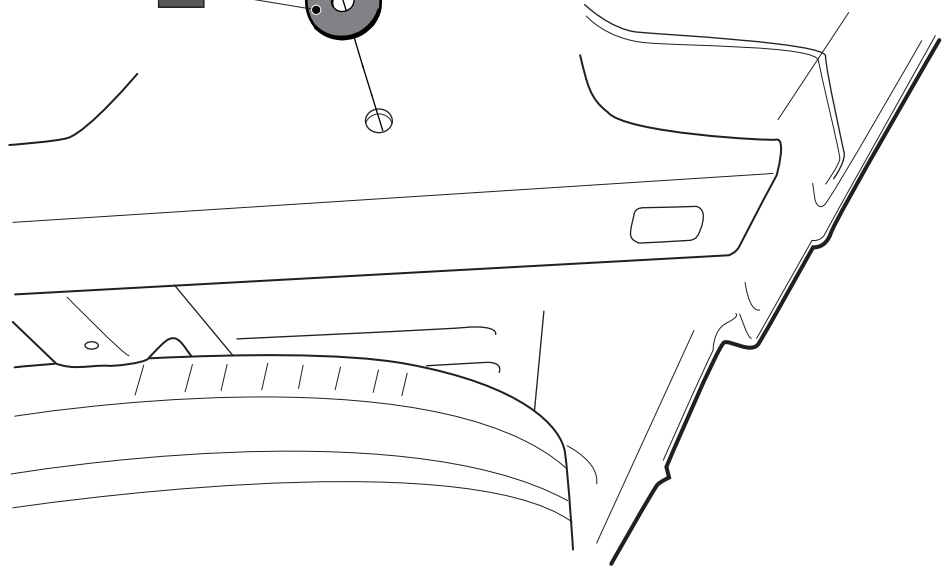
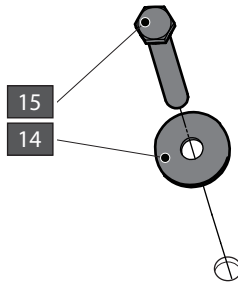

10

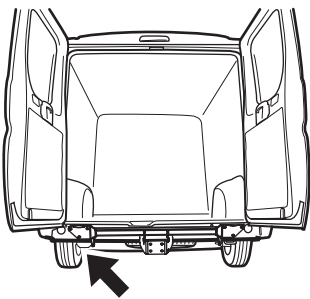

85,0 Nm

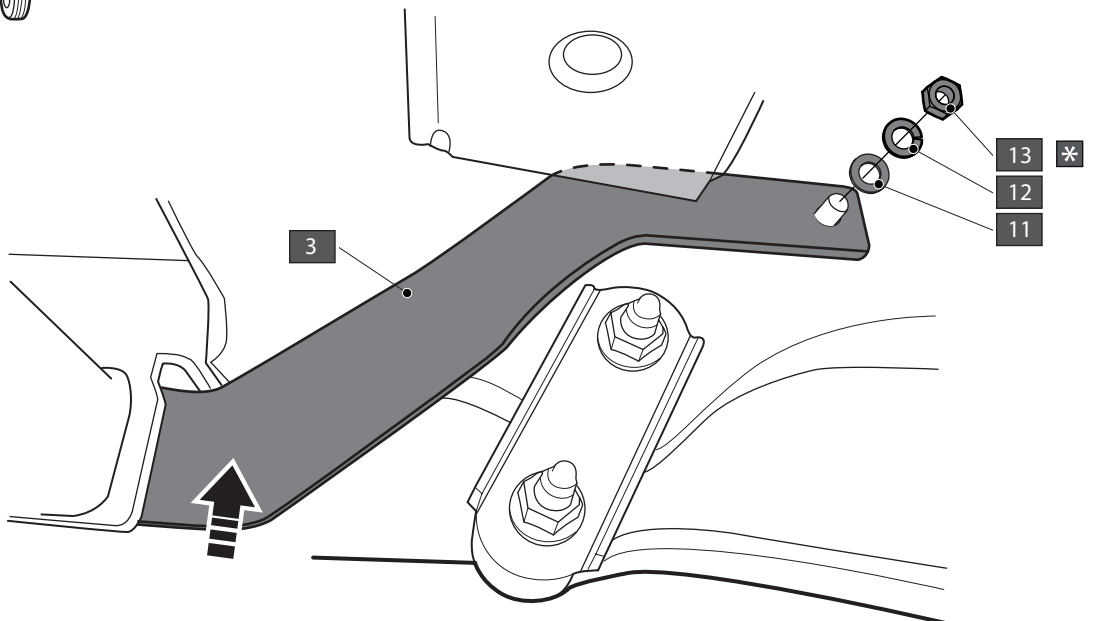
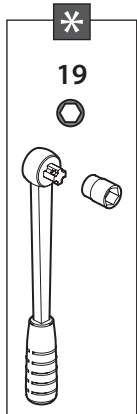

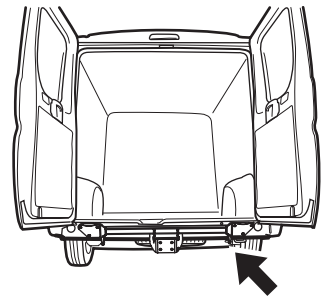
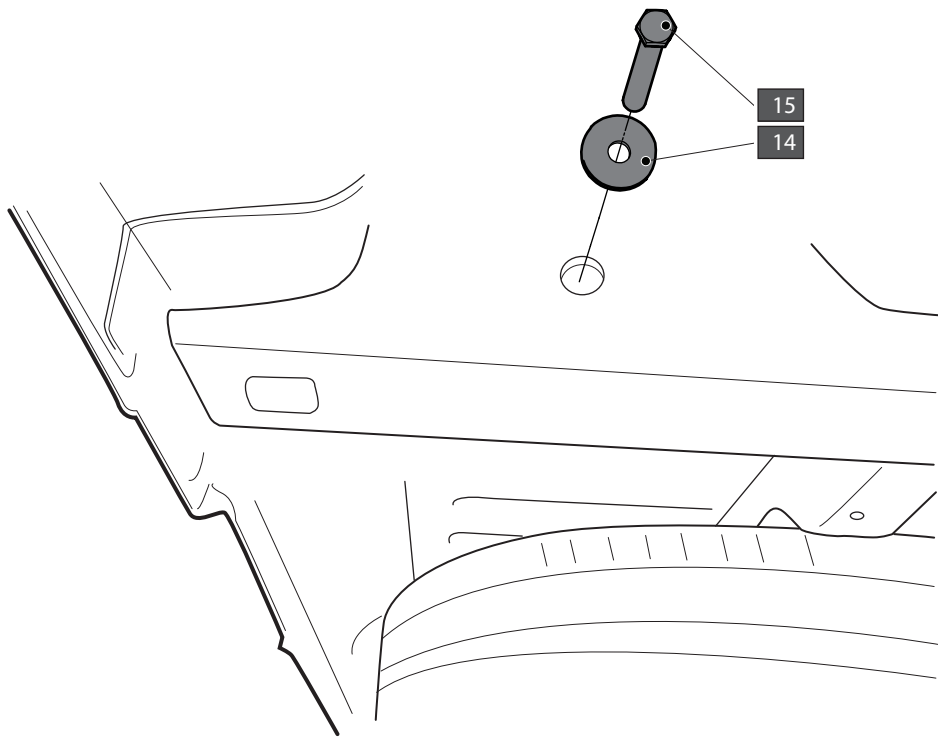

85,0 Nm

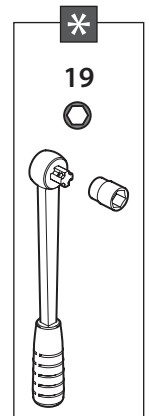
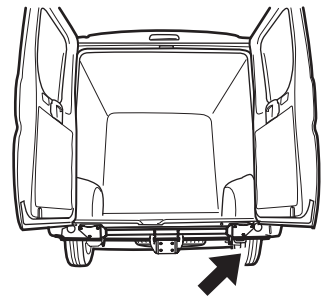
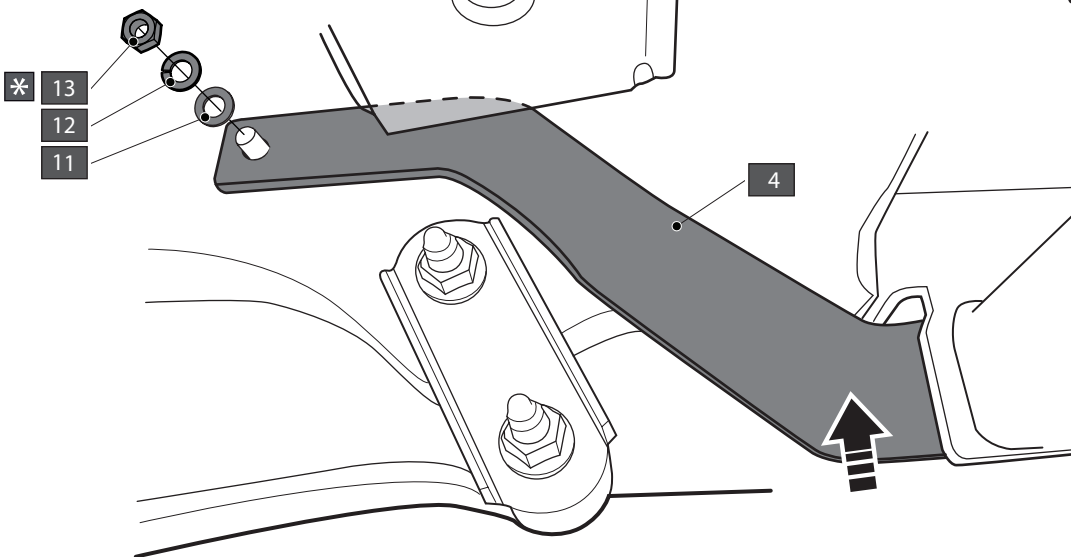

13

Fiat Ducato IV '06 **XL**

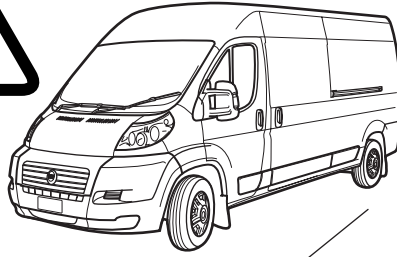
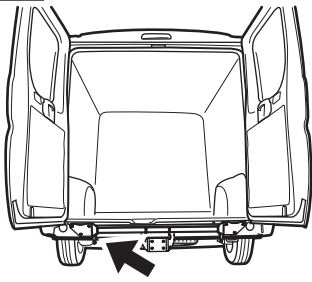

25

Fiat Ducato IV '06 **S-M-L**

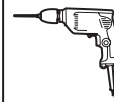

N° OPR: 12947

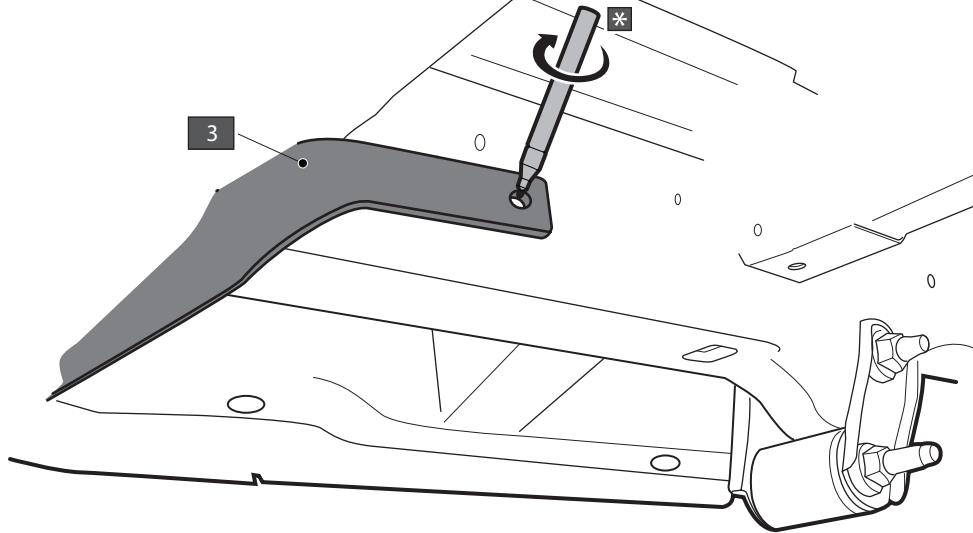
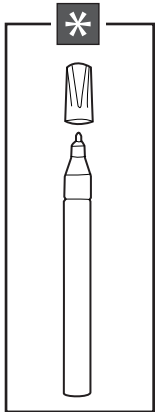

14

Fiat Ducato IV '06 **XL**

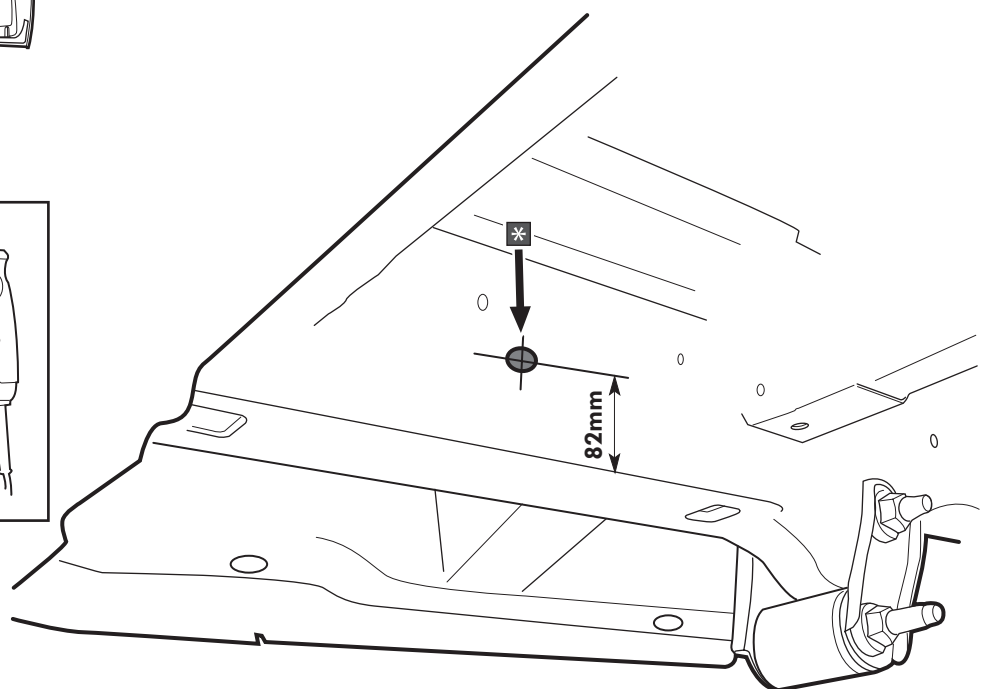
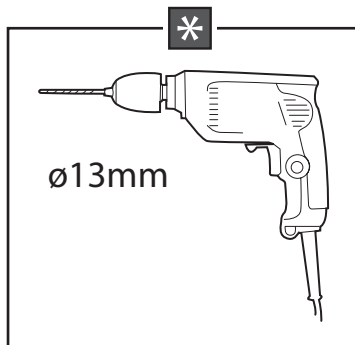
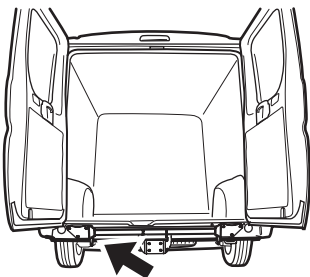

15

Fiat Ducato IV '06 **XL**

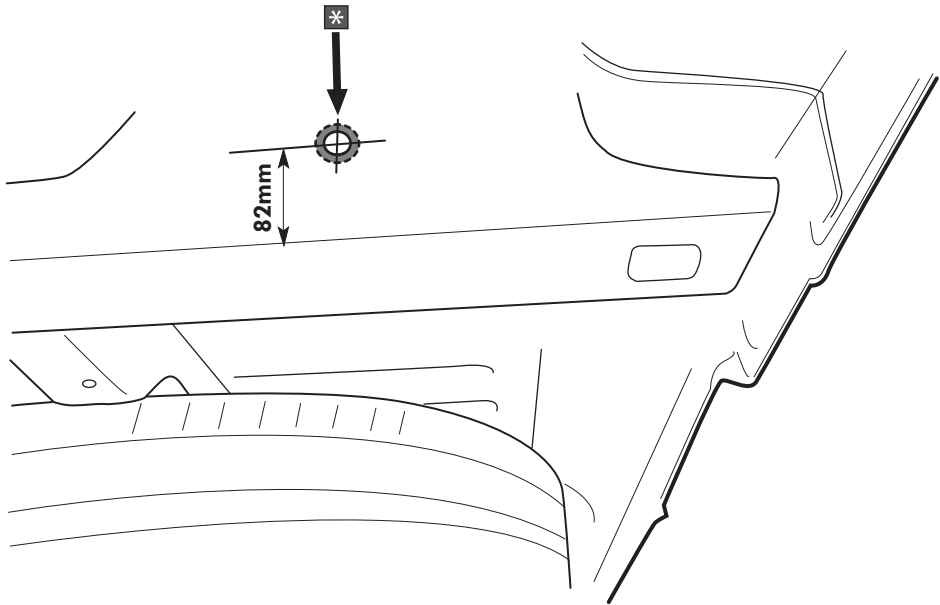
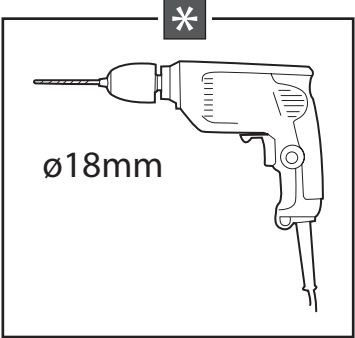
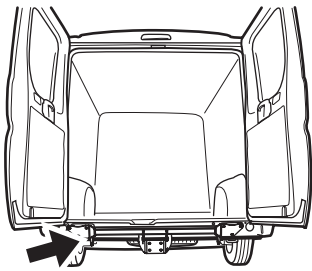

16

Fiat Ducato IV '06 **XL**

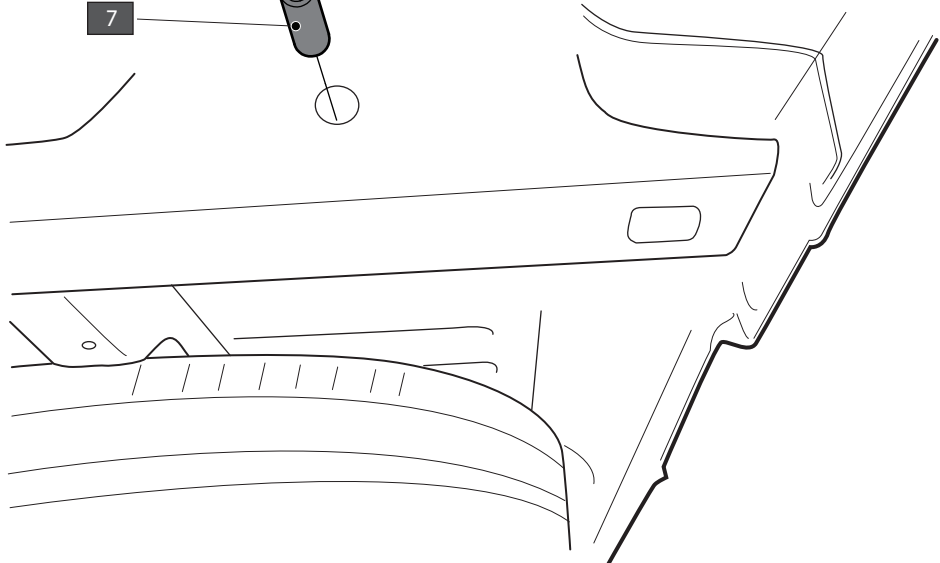
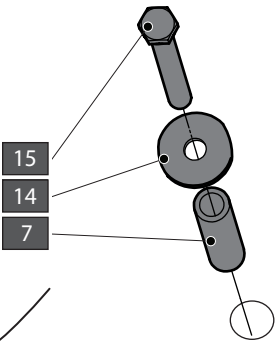
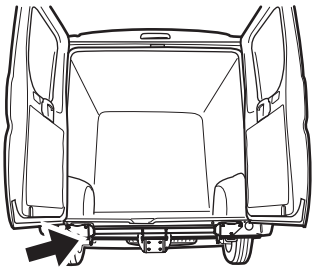

Fiat Ducato IV '06 **XL**

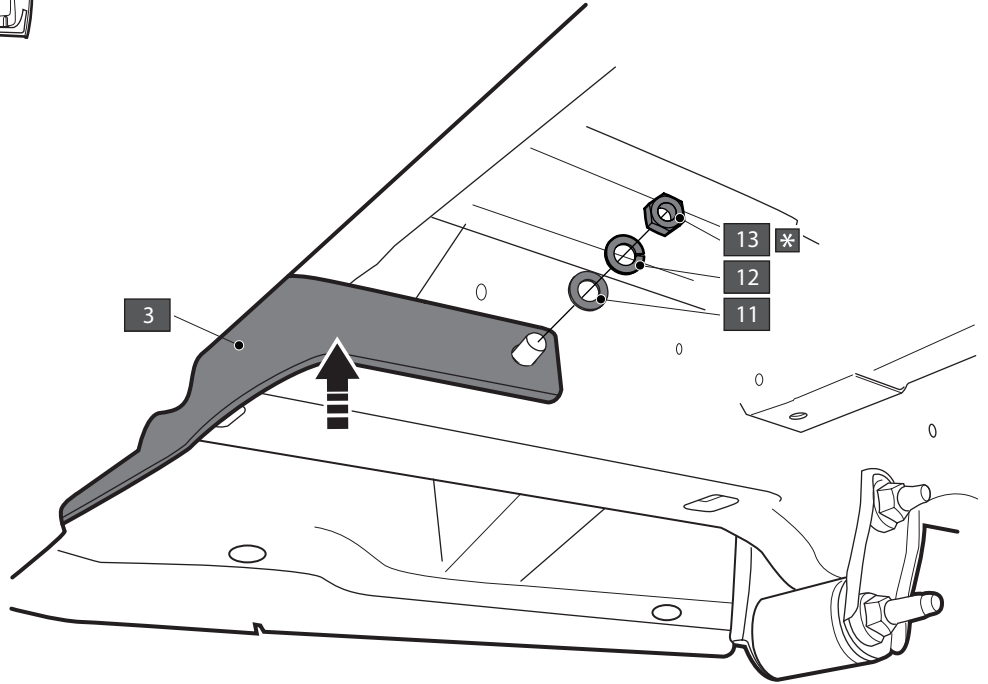
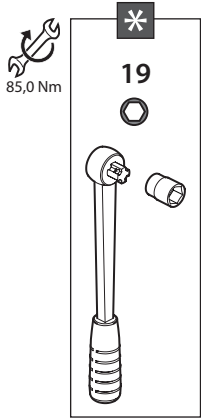
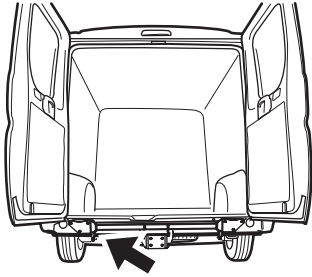

Fiat Ducato IV '06 **XL**

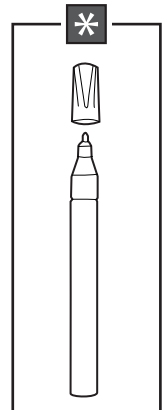
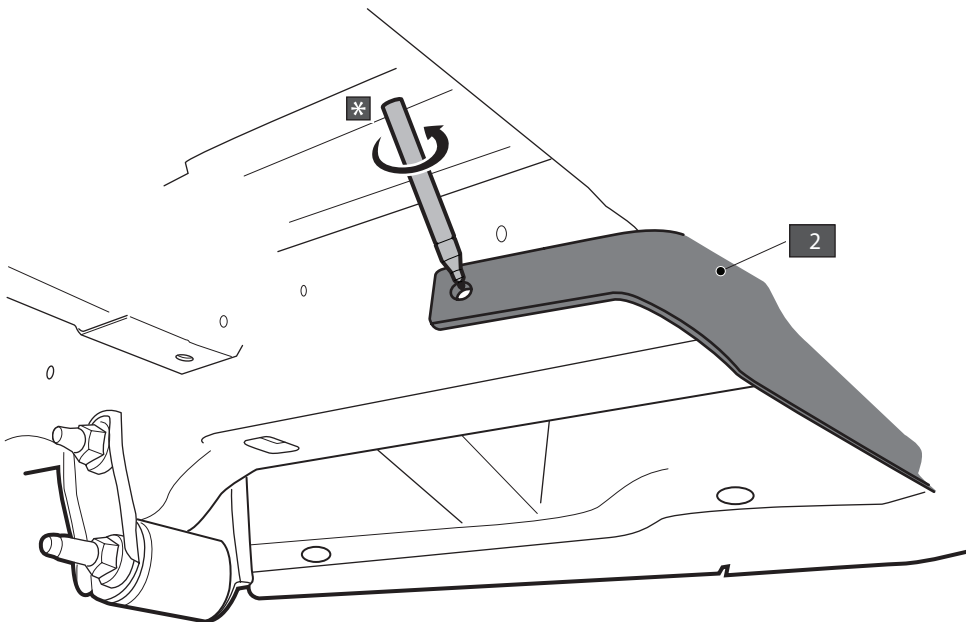
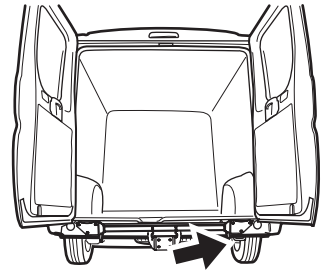

Fiat Ducato IV '06 **XL**

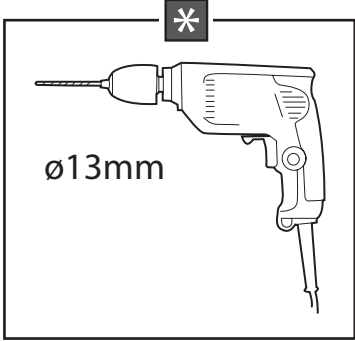
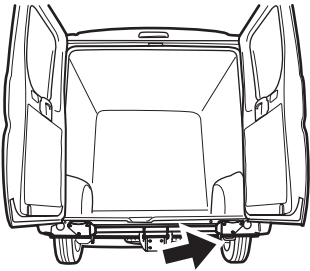
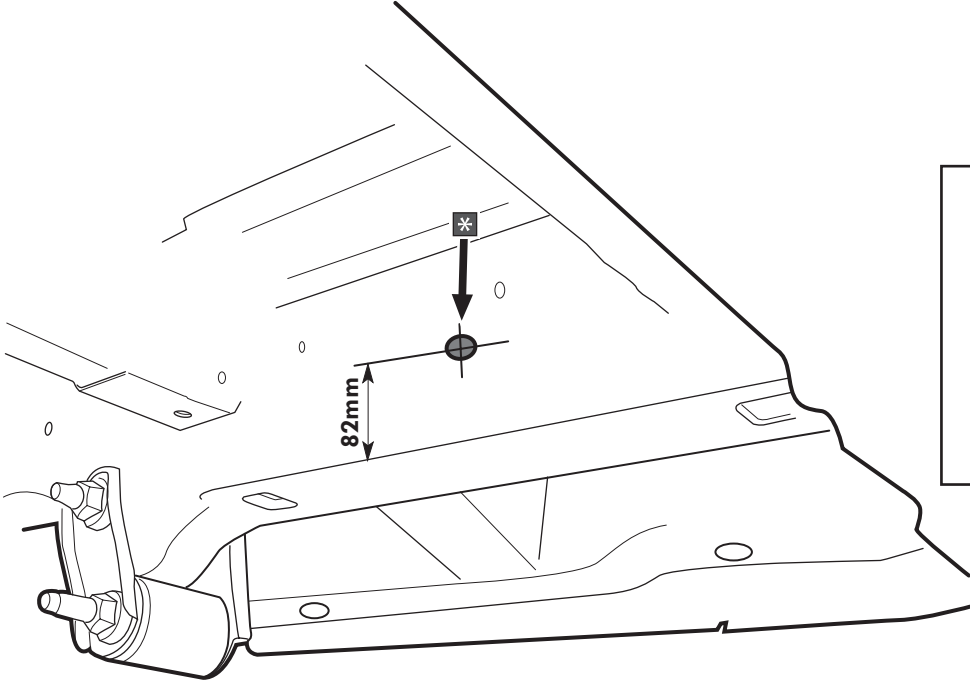

Fiat Ducato IV '06 **XL**

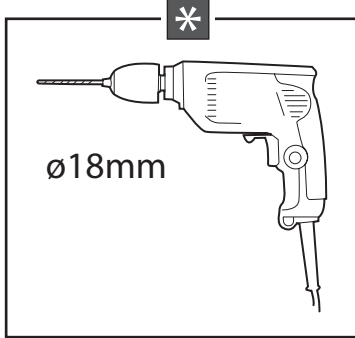
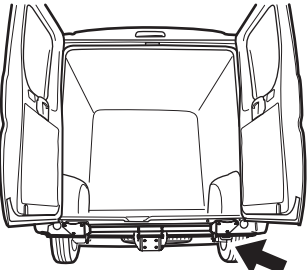
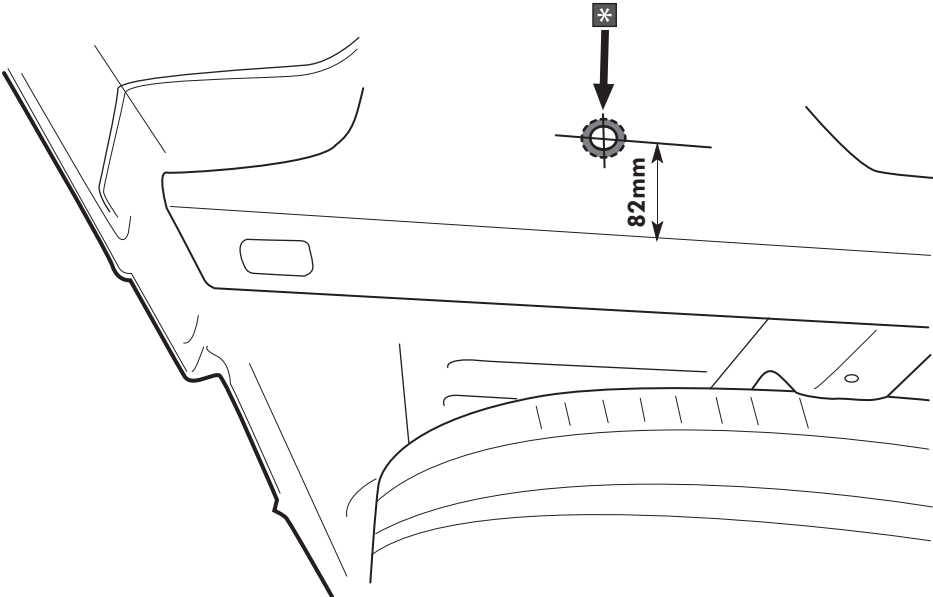

Fiat Ducato IV '06 **XL**

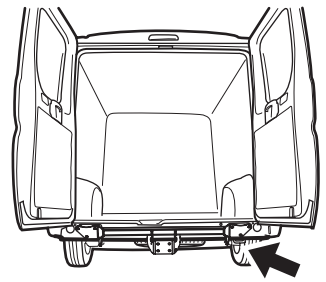
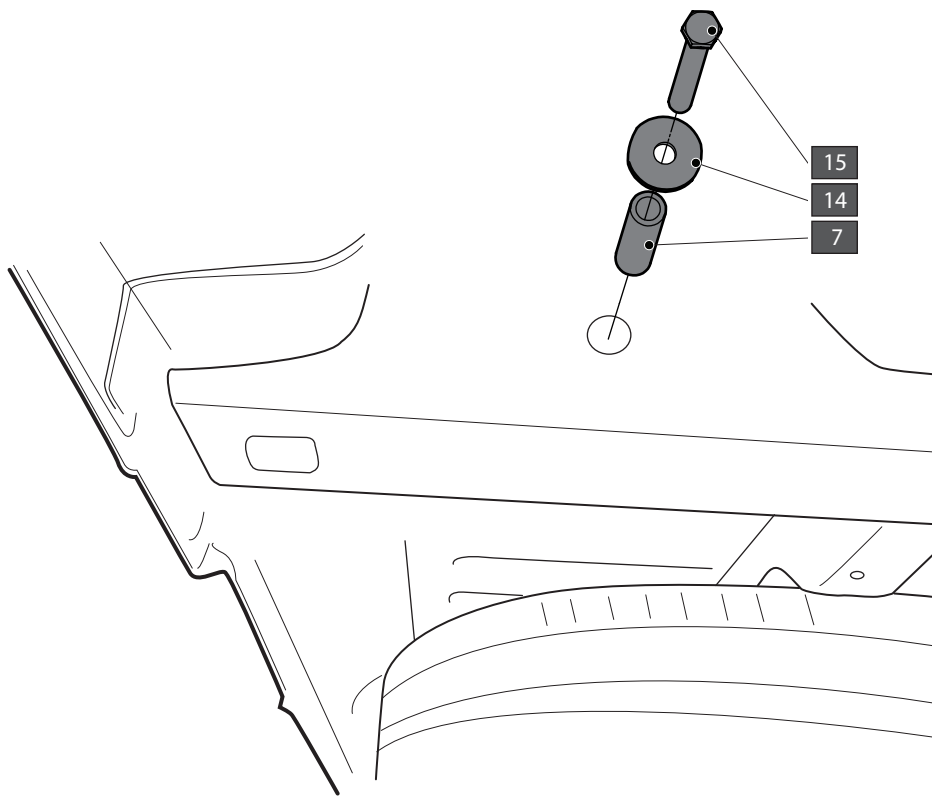

Fiat Ducato IV '06 **XL**

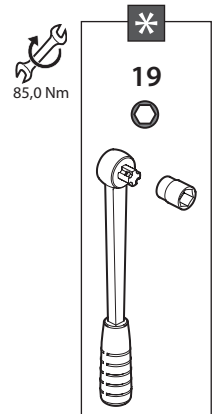
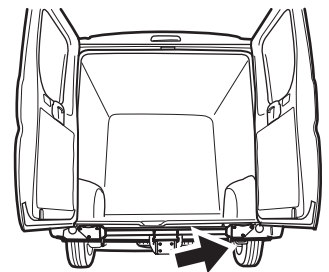
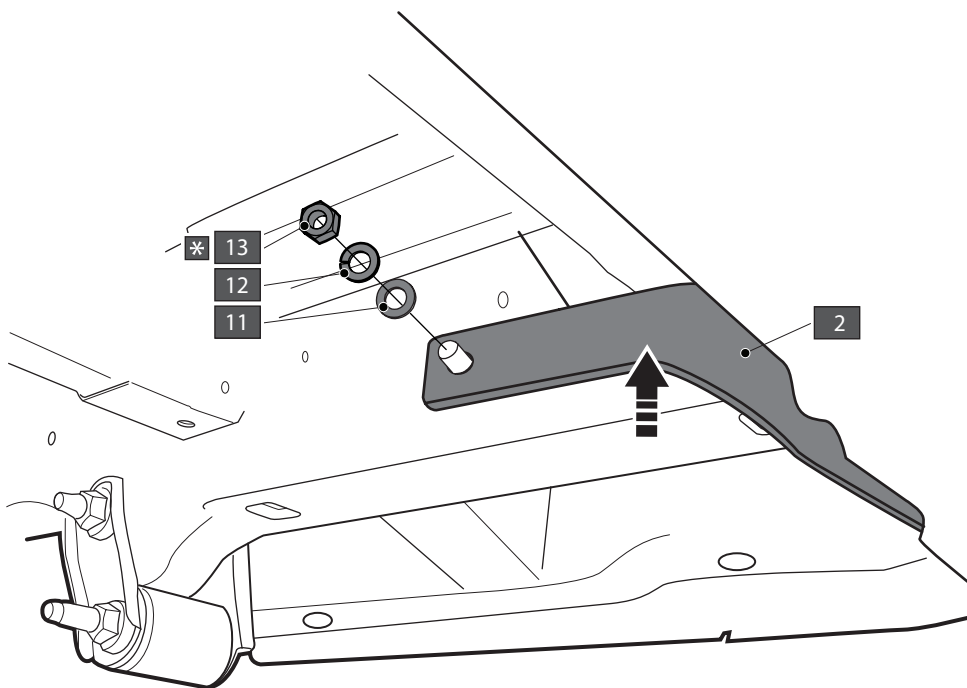

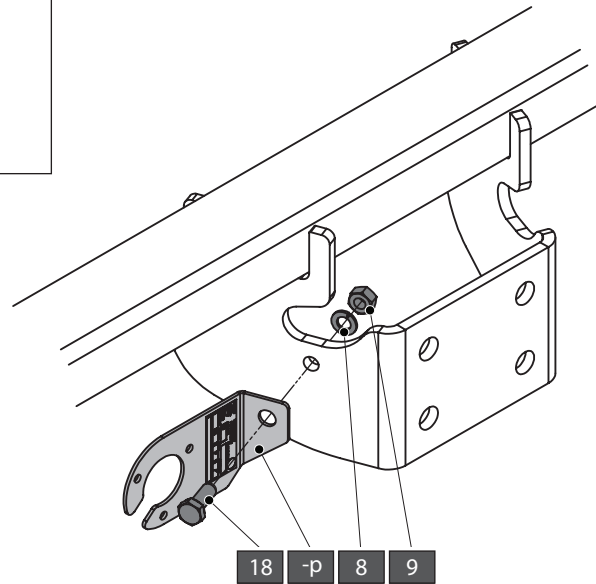
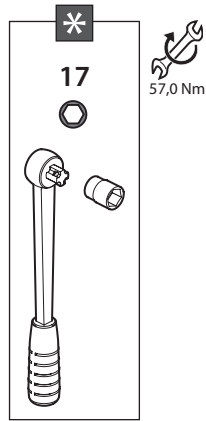
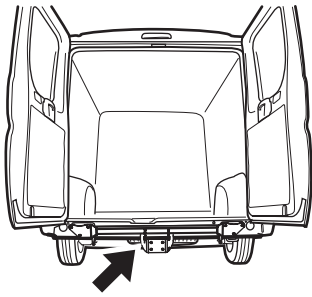

-P



X1

GDW REF. P29

18



X1

DIN933-M10X25 - 1.25

8



X1

DIN128A-M10

9



X1

DIN934-M10 - 1.25

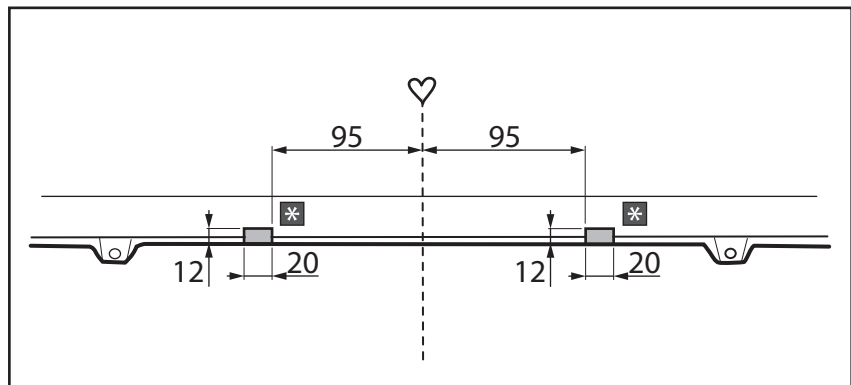
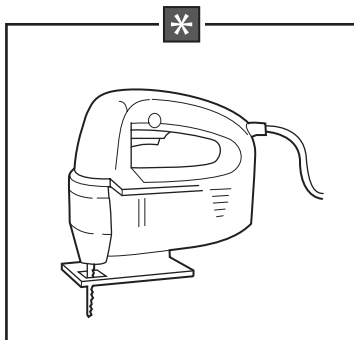
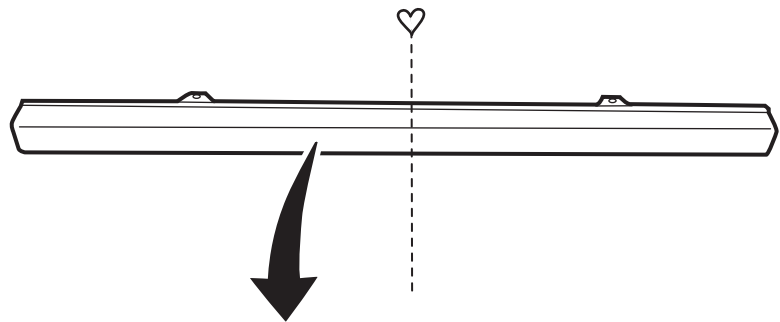
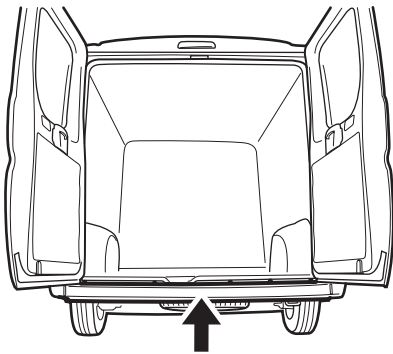



~~PDC~~



28



1

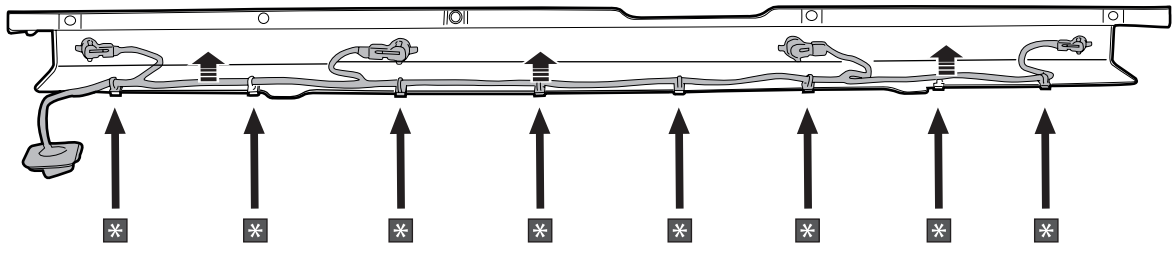
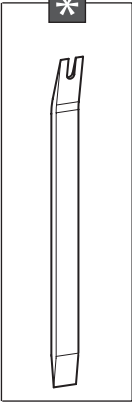

2

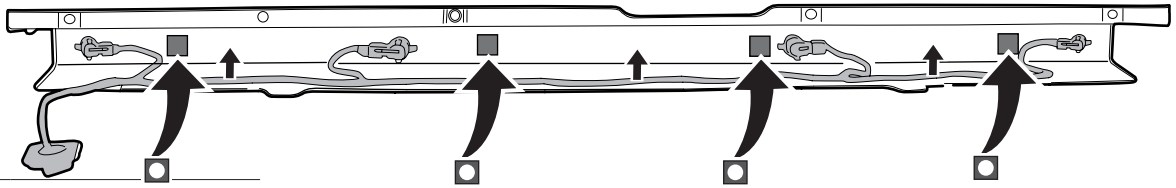

X4 KABELBINDER
16X2,5MM

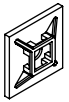

X4 BIND. SOK 28

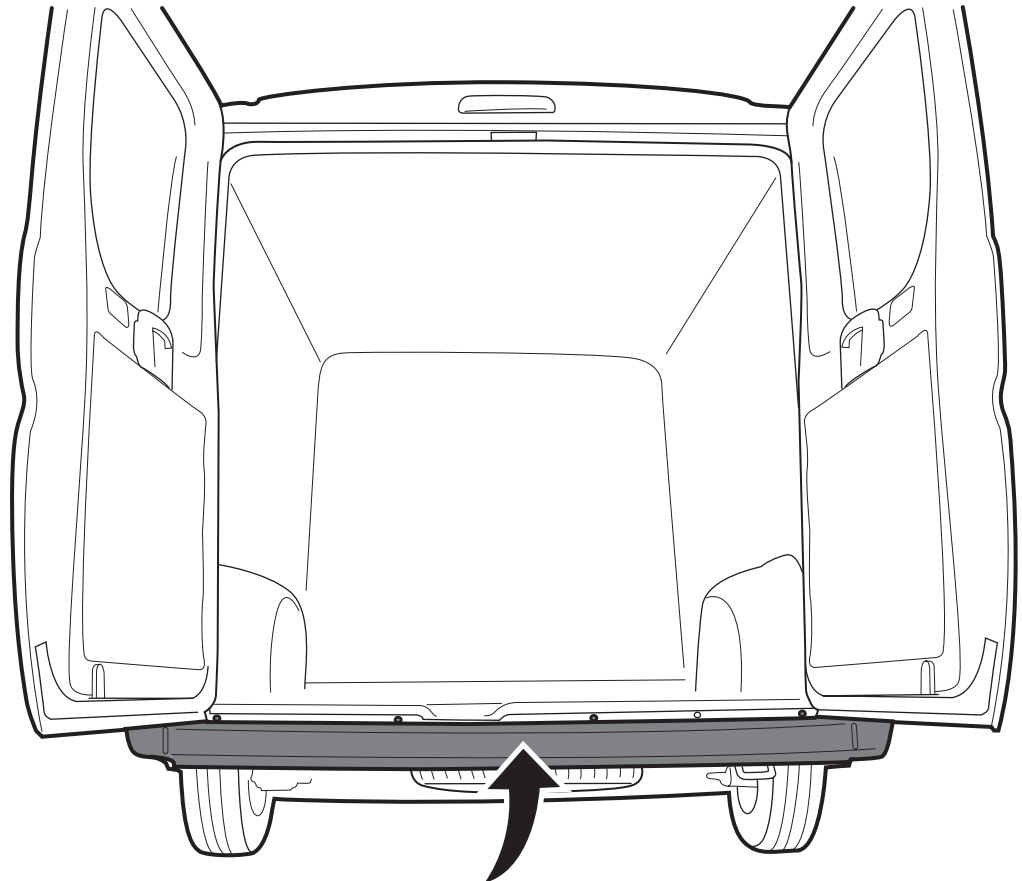

6/8

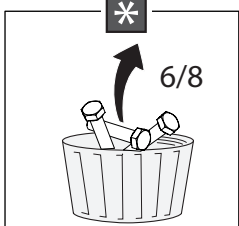

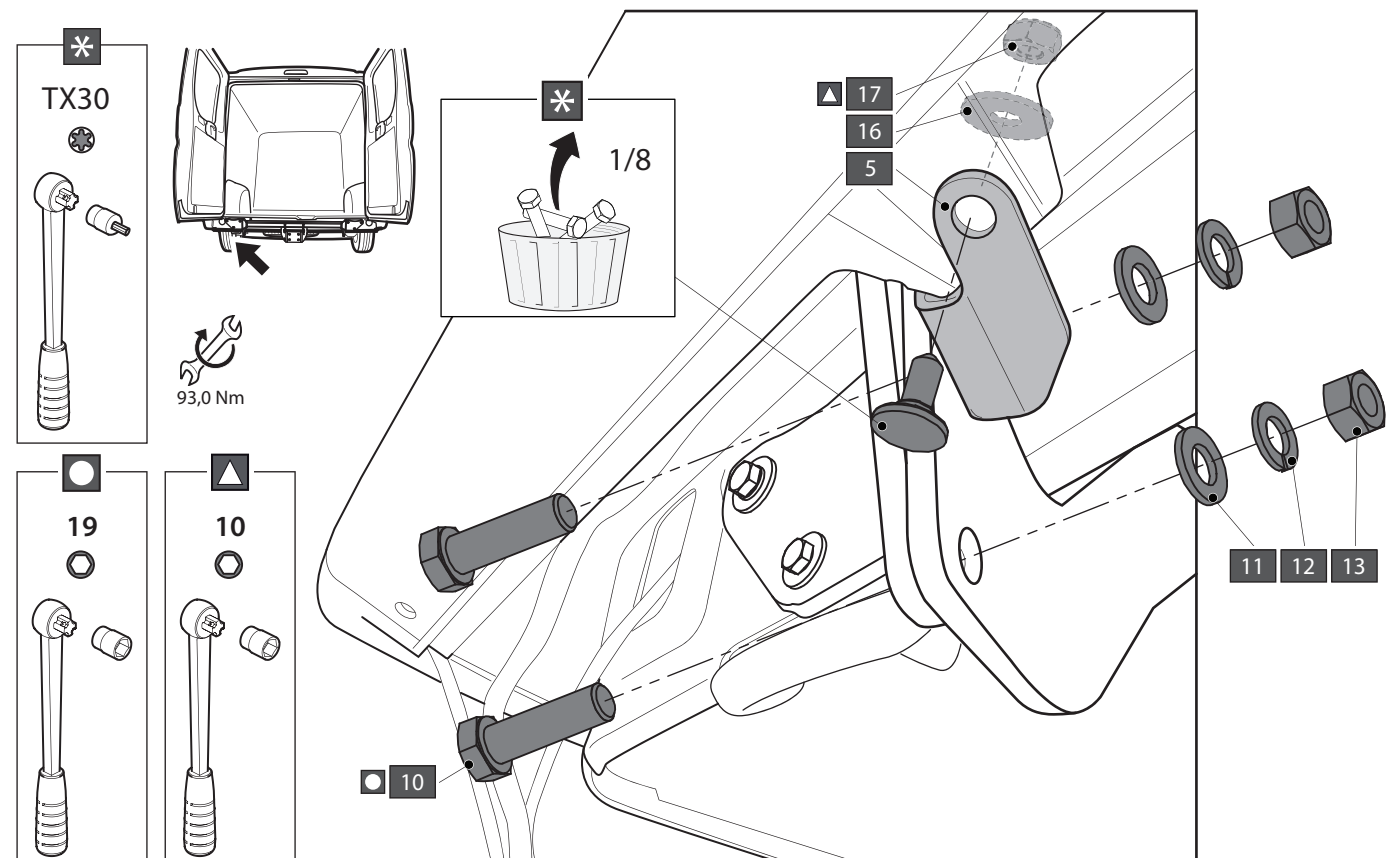
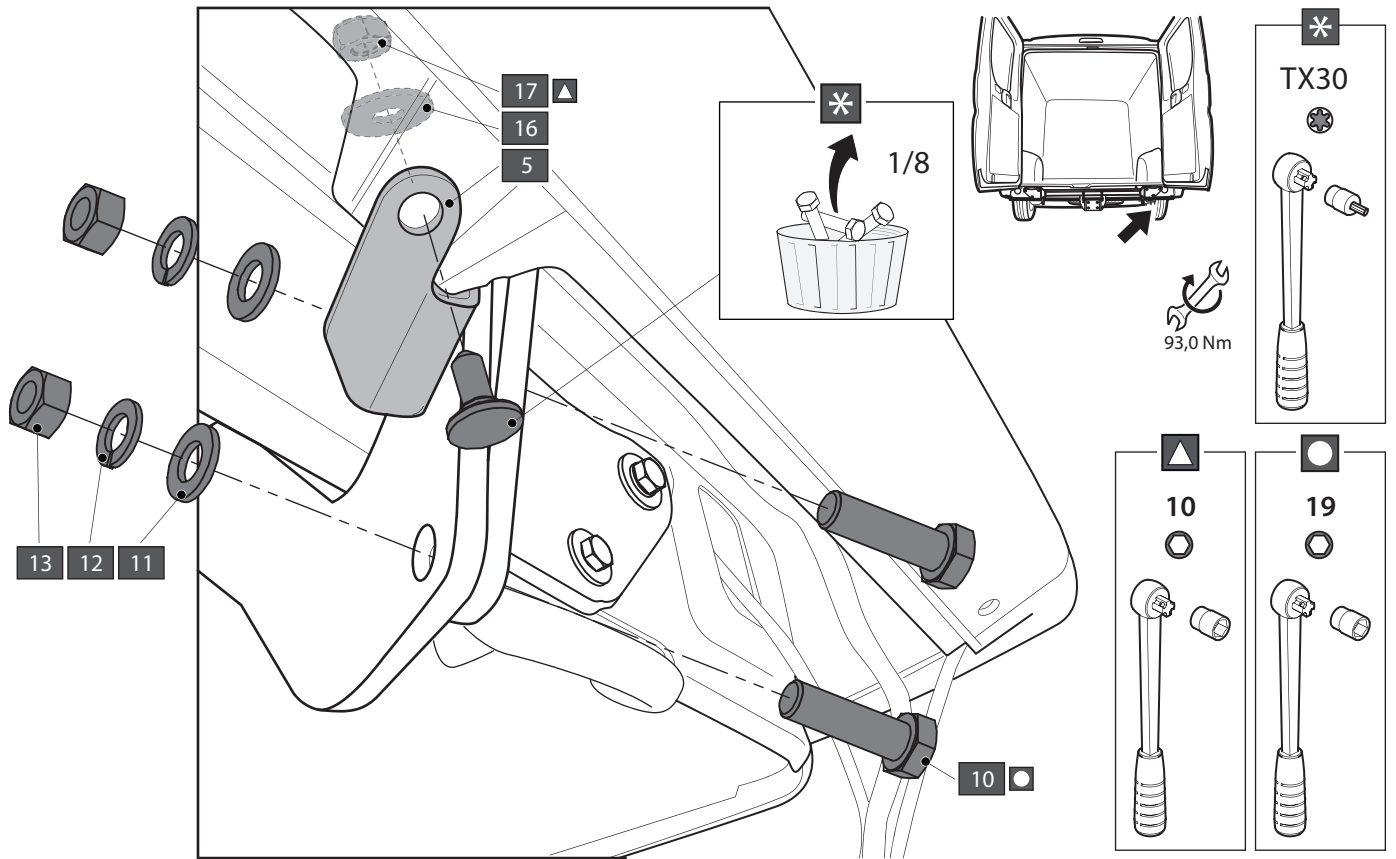

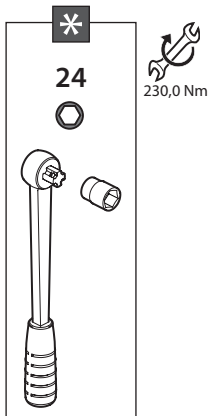
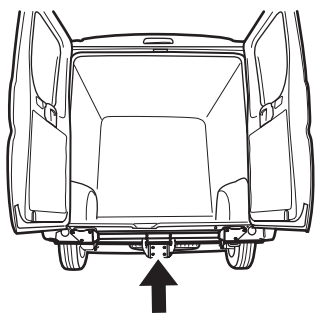

1

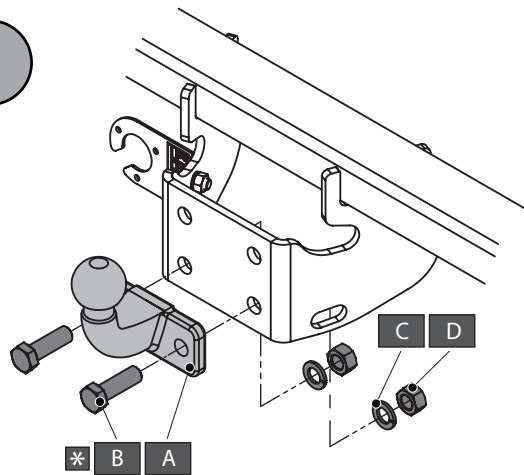

2

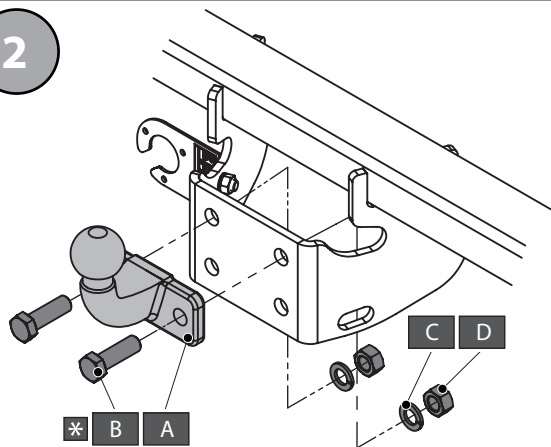

A		X1	740.000
B		X2	DIN933-M16 x 50
C		X2	DIN128A-M16
D		X2	DIN934-M16

!

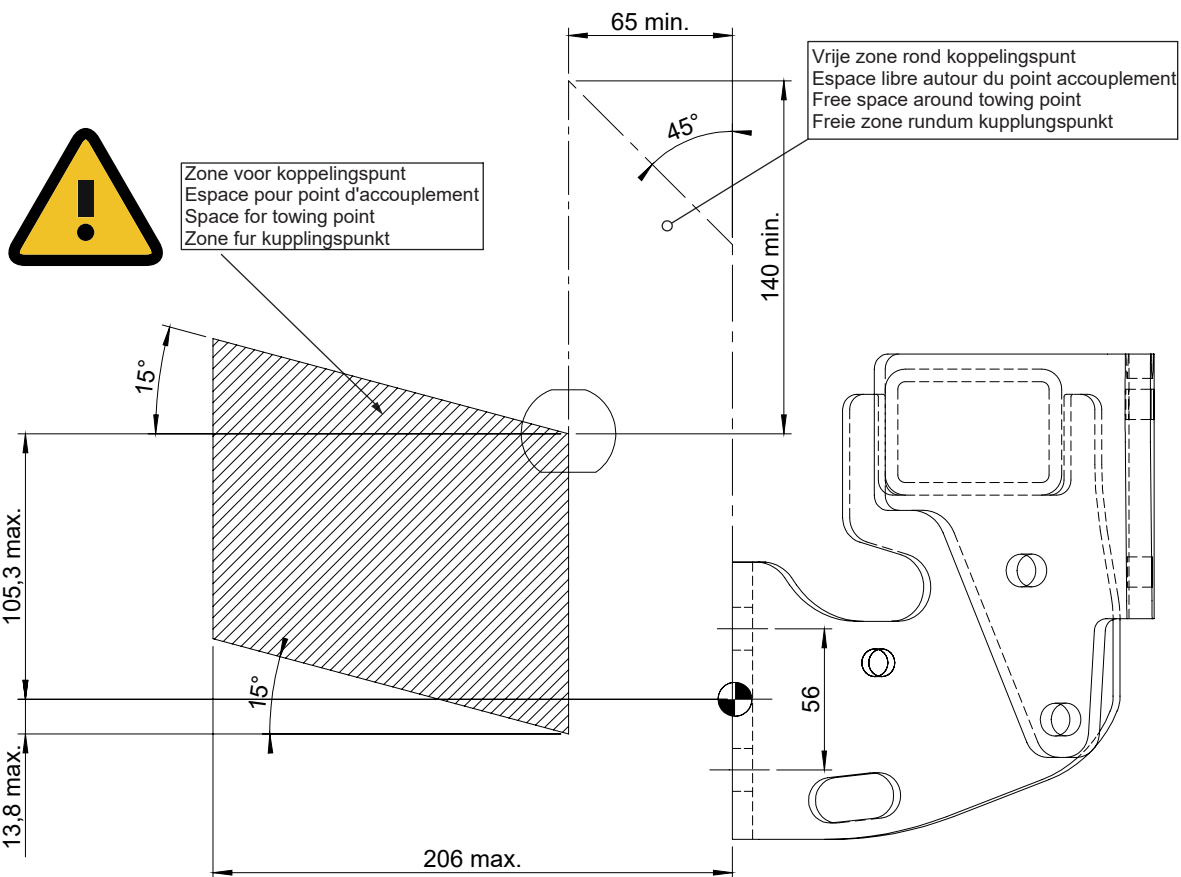

*

RK100WISSE

RK100BASIS

RK100KAP

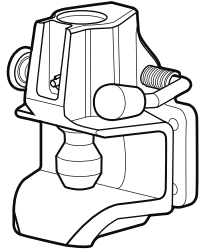

RK243U115E

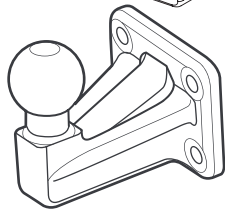

740.010

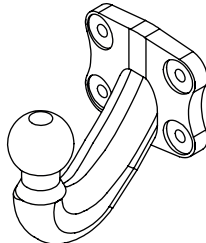

740.011



Art. **ADAPT83x56**

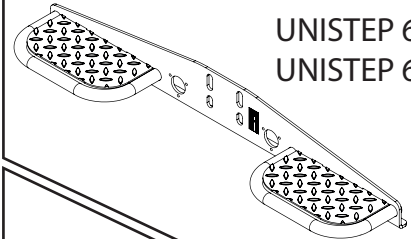

UNISTEP 630.100
UNISTEP 630.110

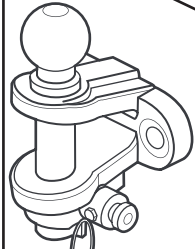

740.043

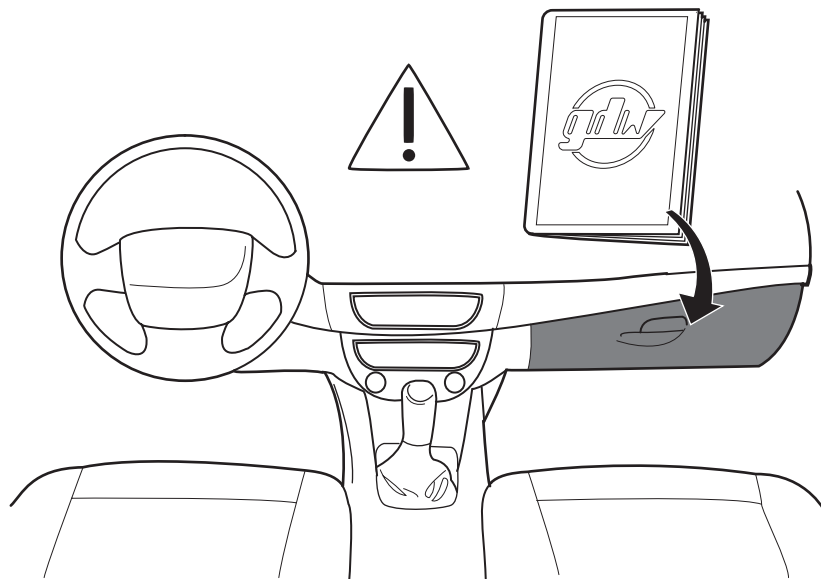
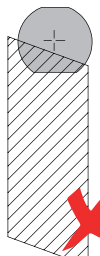
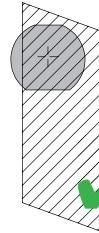
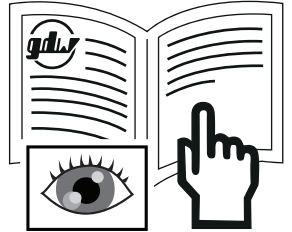

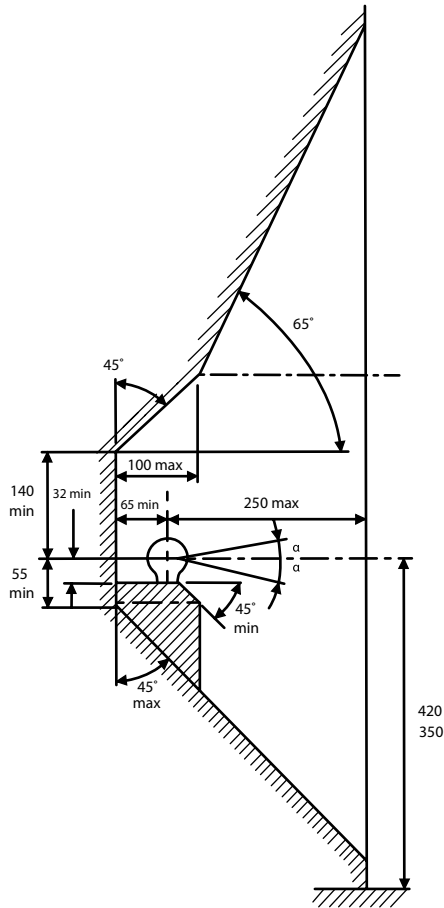

De tussenruimte conform bijlage VII, afbeelding 25 (a, b) van het reglement R55 UN/ECE moet in acht genomen worden.

La zone de dégagement doit être garantie conformément à l'annexe VII, illustration 25 (a, b) de la règle R55 UN/ECE.

The clearance specified in appendix VII, diagram 25 (a, b) of regulation R55 UN/ECE must be guaranteed.

Der Freiraum nach Anhang VII, Abbildung 25 (a, b) der Regulierung R55 UN/ECE ist zu gewährleisten.

Revisar la imagen 25 (a, b) del suplemento VII según la regulación R55 UN/ECE

Spazio libero garantito intorno alla sfera, di cui all'allegato VII, disegni 25 (a, b) del Regolamento R55 UN/ECE.

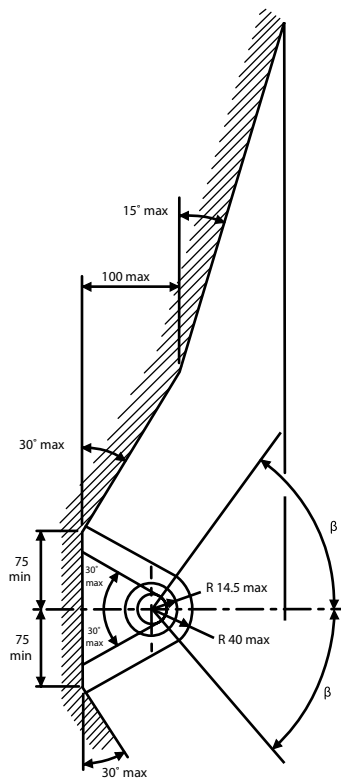

Bij toelaatbaar totaal gewicht van het voertuig

Pour poids total en charge autorisé du véhicule

At laden weight of the vehicle

Bei zulässigem Gesamtgewicht des Fahrzeuges

Peso total admisible del vehículo

Ved tilladt samlet vægt for køretøjet