



# FIAT LINEA

12/06-

Cat. No. F/025

e20

e20\*94/20\*0843\*00

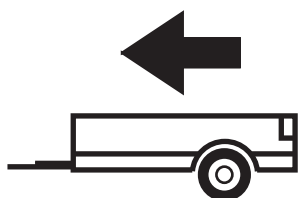

1200kg

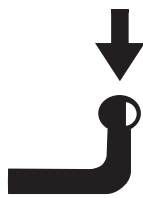

75kg

**D** = 7,30kN

**D (kN) =**



MAX kg

x

MAX kg

x 0,00981



MAX kg

+

MAX kg

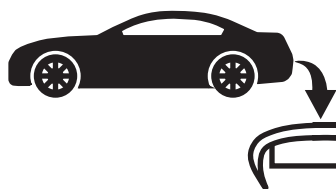

IMIOLA HAK-POL

96-111 KOWIESY, CHOJNATA 23A, POLAND

Tel. + 48 46 831 73 31, fax +48 831 74 29

e-mail: office@imiola.pl, www.imiola.pl

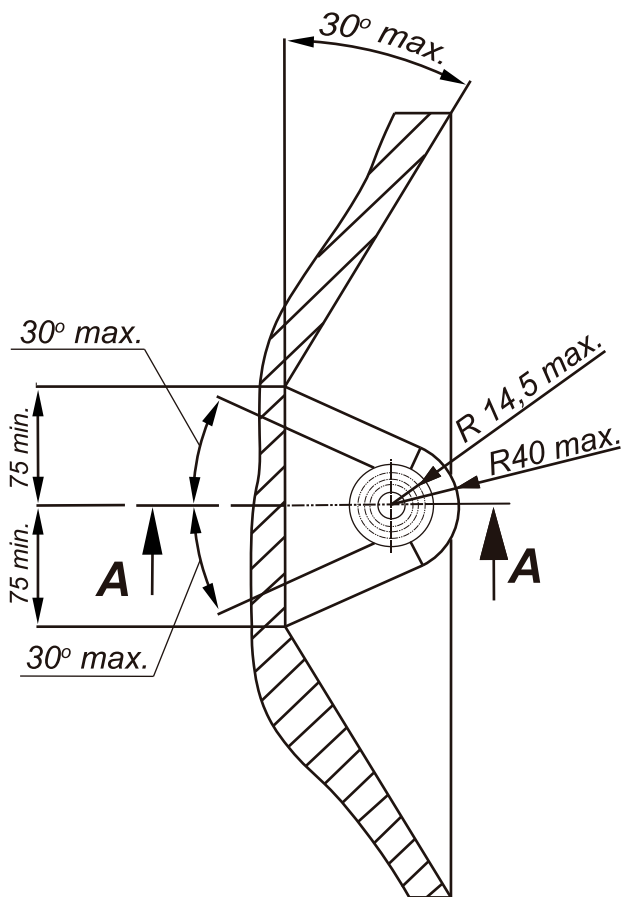

## PRZEKRÓJ A-A

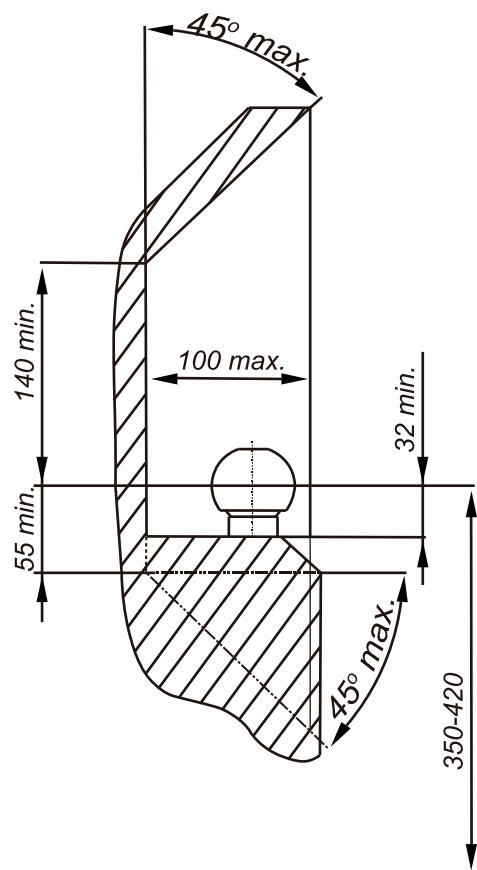

**PL** Należy zagwarantować przestrzeń swobodną według załącznika VII, rysunek 25a/b Regulaminu EKG ONZ 55.01 przy dopuszczalnym ciężarze całkowitym pojazdu.

**F** L'espace libre doit être garanti conformément à l'annexe VII, illustration de la réglementation 55.01 CE pour un poids total en charge autorisé du véhicule.

**GB** The clearance specified in appendix VII, diagram 25a/b of Regulation No. 55.01 UN EU must be guaranteed at laden weight of the vehicle.

**D** Der Freiraum nach Anhang VII, Abbildung 25a/b der Vorschriften 55.01 EG ist zu gewährleisten bei zulässigem Gesamtgewicht des Fahrzeuges.

Moment skracający dla śrub i nakrętek (8.8) Torque settings for nuts and bolts (8.8)	
M8	25Nm
M10	55Nm
M12	85Nm
M14	135Nm
M16	195Nm

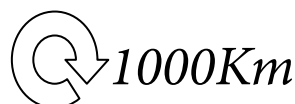

Šruba M10x35-8.8 ; Bolt  
 Podkl. sprež. 10,2 ; Spring Washer  
 Podkl. okr. Ø30x Ø10,5x 3 ; Plain Washer

Šruba M10x35-8.8 ; Bolt

Šruba M10x35-8.8 ; Bolt

Nakretka M 8 ; Nut  
 Podkl. sprež. 8,2 ; Spring Washer  
 Podkl. okr. Ø23x Ø8,5x 2 ; Plain Washer

Nakretka M12 ; Nut  
 Podkl. sprež. 12,2 ; Spring Washer  
 Podkl. okr. 13 ; Plain Washer









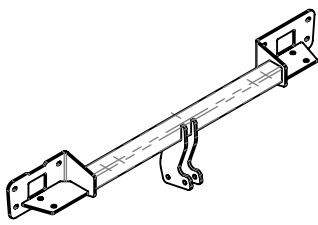
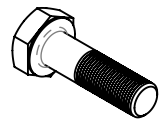
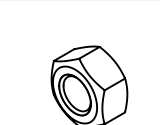
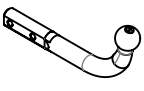

Nakretka M10 ; Nut  
 Podkl. sprež. 10,2 ; Spring Washer  
 Podkl. okr. Ø30x Ø10,5x 3 ; Plain Washer

Šruba M10x35-8.8 ; Bolt  
 Podkl. sprež. 10,2 ; Spring Washer  
 Podkl. okr. Ø30x Ø10,5x 3 ; Plain Washer

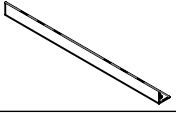
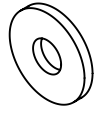
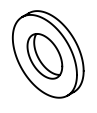
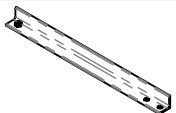
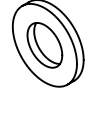
Nakretka M10 ; Nut  
 Podkl. sprež. 10,2 ; Spring Washer  
 Podkl. okr. Ø30x Ø10,5x 3 ; Plain Washer

Šruba M12x70-8.8 ; Bolt

Nakretka M 8 ; Nut  
 Podkl. sprež. 8,2 ; Spring Washer  
 Podkl. okr. Ø23x Ø8,5x 2 ; Plain Washer

	A	x1		M12x70	2
				M10x35	6
	B	x1		M12	2
				M10	4
				M8	6
	C	x1		Ø30xØ10,5x3	6
				Ø23xØ8,5x2	6
	D	x1		13	2
				12,2	2
	E	x1		10,2	6
				8,2	6
	F	x1			
	G	x1			

Śruba M10x35-8.8 ; Bolt  
Podkl. spręż. 10,2 ; Spring Washer  
Podkl. okr. Ø30x Ø10,5x 3 ; Plain Washer

Śruba M10x35-8.8 ; Bolt

E Pkt. 1

D

Pkt. 2

Pkt. 3

F

A

G

B

Nakrętka M12 ; Nut  
Podkl. spręż. 12,2 ; Spring Washer  
Podkl. okr. 13 ; Plain Washer

Nakrętka M8 ; Nut  
Podkl. spręż. 8,2 ; Spring Washer  
Podkl. okr. Ø23x Ø8,5x 2 ; Plain Washer

Nakrętka M10 ; Nut  
Podkl. spręż. 10,2 ; Spring Washer  
Podkl. okr. Ø30x Ø10,5x 3 ; Plain Washer

Nakrętka M8 ; Nut  
Podkl. spręż. 8,2 ; Spring Washer  
Podkl. okr. Ø23x Ø8,5x 2 ; Plain Washer

Śruba M12x70-8.8 ; Bolt

Śruba M10x35-8.8 ; Bolt

Pkt. 1

E

C

Pkt. 2

Pkt. 3

F

A

G

B

Nakrętka M12 ; Nut  
Podkl. spręż. 12,2 ; Spring Washer  
Podkl. okr. 13 ; Plain Washer

Nakrętka M8 ; Nut  
Podkl. spręż. 8,2 ; Spring Washer  
Podkl. okr. Ø23x Ø8,5x 2 ; Plain Washer

Nakrętka M10 ; Nut  
Podkl. spręż. 10,2 ; Spring Washer  
Podkl. okr. Ø30x Ø10,5x 3 ; Plain Washer

Śruba M12x70-8.8 ; Bolt



- Odkręcić zderzak oraz lampy.
- Odkręcić belkę zderzeniową (nie będzie już wykorzystana).
- Wykonać otwory 65x45 w tylnym pasie samochodu po obydwu końcach podłużnic (wg rys.).
- Elementy haka C i D wsunąć do podłużnic i poprzez technologiczne otwory przykręcić śrubami M10x35 8.8 (pkt 1).
- Belkę haka A nałożyć na wystające śruby M8 w tylnym pasie i dokręcić nakrętki M8 (pkt 3).
- Elementy haka C i D przykręcić do belki haka A śrubami M10x35 8.8 (pkt 2).
- Dokręcić wszystkie śruby z momentem jak w tabeli.
- Wykonać wycięcie w dolnej części zderzaka, w jego osi o wymiarach 50x100.
- Przykręcić zderzak oraz lampy.
- Przykręcić kulę i blachę gniazda elektrycznego.
- Podłączyć instalację elektryczną.

- Unscrew the bumper and lights.
- Unscrew the bumper bar (it will not be used any more).
- Drill the holes 65x45 in the rear belt of the car after both ends of the metal clamps (according to the drawing).
- Insert the elements C and D in the metal clamps and screw with bolts M10x35 8.8 (point 1), through the technological holes.
- Put the main bar A on the protruding bolts M8 in the rear belt and tighten nuts M8 (point 3).
- Screw the elements C and D to the main bar A with bolts M10x35 8.8 (point 2).
- Tighten all the bolts according to the torque setting- see the table.
- Cut out the fragment 50x100 in the lower part of the bumper, in its axle.
- Screw the bumper and lights.
- Fix the ball and electric plate.
- Connect the electric wires.

- Dévisser le pare-chocs et les lampes.
- Dévisser la poutre de choc (elle ne sera plus utilisée).
- Faire les trous aux dimensions 65x45 dans la jupe arrière de la voiture dans les deux extrémités des longerons (selon le dessin).
- Insérer les éléments C et D du crochet dans les longerons et serrer par les trous technologiques à l'aide des boulons M10x35 8.8 (point 1).
- Mettre la poutre du crochet A sur les boulons M8 dans la jupe arrière et serrer les écrous M8 (point 3).
- Visser les éléments C et D du crochet à la poutre du crochet A à l'aide des boulons M10x35 8.8 (point 2).
- Serrer tous les boulons avec un couple de serrage selon tableau.
- Dans la partie inférieure du pare-chocs, dans son axe, couper un fragment aux dimensions 50x100.
- Monter le pare-chocs et les lampes.
- Visser le crochet d'attelage et socle de prise électrique.
- Raccorder le circuit électrique.

- Die Stoßstange und die Lichter abschrauben.
- Den Stoßstangestreifen abschrauben (wird nicht wieder benutzt).
- Die Önungen 65x45 im hinteren Karosseriestreifen auf beiden Längsträger Endungen nach der Zeichnung ausführen.
- Die Tragteile C und D in die Längsträger schieben und durch die vom Werk aus vorhandenen Önungen mit den Schrauben M10x35 8.8 (Punkt 1) anschrauben.
- Den Querbalken A auf die herausragenden Schrauben M8 im hinteren Karosseriestreifen aufsetzen und die Muttern M8 (Punkt 3) festschrauben.
- Die Tragteile C und D an den Querbalken A mit den Schrauben M10x35 8.8 (Punkt 2) anschrauben.
- Alle Schrauben mit dem in der Tabelle angegebenen Drehmoment festziehen.
- Einen Ausschnitt im unteren Teil der Stoßstange, in ihrer Achse 50x100 ausführen.
- Die Stoßstange und die Lichter anschrauben.
- Die Kugel und die Steckdosenhalterung anschrauben.
- Die Elektroinstallation anschließen.

- Desenroscar la luces traseras y parachoques
- Desenroscar el realzar del parachoques (ya no se utilizará)
- Hacer cortes en ambos lados de la correa trasera 65x45.
- Insertar los elementos C y D al chasis y apretar ligeramente con tornillos M10x35 8.8 (punto 1).
- Apretar la barra del gancho A al latón trasero con tuercas M8 8.8 (punto 2).
- Apretar los elementos C y D a la barra A con tornillos M10x35 8.8 (punto 3).
- Cortar la parte inferior del parachoques en su eje, un pedazo de 50x100
- Apretar todos los tornillos con el par según la tabla anterior.
- Apretar el parachoques y las luces traseras.
- Apretar la bola y la placa de la toma de corriente.
- Conectar la instalación eléctrica.

